



PERISTALTIC METERING PUMPS SINCE 1957

BASIC SERVICE MANUAL

CLASSIC SERIES WITH QuickPro® PUMP HEAD

 WARNING

To be installed and maintained by properly trained professional installer only.
Read manual & labels for all safety information & instructions.

BASIC SERVICE MANUAL

CLASSIC SERIES WITH QuickPro® PUMP HEAD

The Stenner Classic Series peristaltic metering pumps are mechanical and during their service life will require scheduled maintenance. The purpose of this manual is to identify the parts that will eventually require replacement, along with other maintenance basics. Best practice tips and corrective actions are also in this manual.

ICONS USED IN THIS MANUAL



Factory Instructions



Important Information



Additional Information

TRADEMARKS

QuickPro® is a registered trademark of the Stenner Pump Company.

Santoprene® is a registered trademark of Exxon Mobil Corporation.

AquaShield™ is a trademark of Houghton International.

TABLE OF CONTENTS

SECTION I - GENERAL INFORMATION

| | |
|---------------------------------------|---|
| SAFETY INFORMATION | 5 |
| TOOL LIST AND CLEANING SUPPLIES | 6 |
| CLASSIC SERIES PUMP | 7 |

SECTION II - INSTALLATION POINTS

| | |
|-----------------------------------|----|
| INSTALLATION DIAGRAM | 8 |
| VERTICAL INSTALLATION | 9 |
| SUCTION AND DISCHARGE LINES | 10 |
| COMPRESSION SEAL | 11 |

SECTION III - SUBASSEMBLY CONNECTIONS

| | |
|---------------------------------------|----|
| RIVET AND SLOT IDENTIFICATION | 12 |
| SEPARATING SUBASSEMBLIES | 13 |
| RECONNECTING FEED RATE TO MOTOR | 14 |

SECTION IV - PUMP TUBE

| | |
|---|-------|
| PUMP TUBE BASICS | 15 |
| VISUAL REFERENCE | 16 |
| CONDITIONS THAT REDUCE PUMP TUBE LIFE | 17-20 |
| IMPORTANT PUMP TUBE INFORMATION | 21 |
| TUBE REPLACEMENT | 22-30 |
| PUMP HEAD REPLACEMENT | 31-33 |

SECTION V - FEED RATE CONTROL (FRC)

| | |
|-----------------------------------|-------|
| FEED RATE CONTROL | 34 |
| FEED RATE WEAR | 35-36 |
| FEED RATE PARTS REPLACEMENT | 37-38 |

SECTION VI - MOTOR

| | |
|---------------------------------------|-------|
| MOTOR | 39 |
| CAUSES OF MOTOR MALFUNCTION | 40 |
| ROTOR ASSEMBLY REPLACEMENT | 41 |
| COIL REPLACEMENT | 42-45 |
| GEARS & GEAR SET IDENTIFICATION | 46 |
| GEAR WEAR | 47 |
| GEAR REPLACEMENT | 48 |

SAFETY INFORMATION

 **NOTICE:** Before installing or servicing the pump, read the pump manual for all safety information and complete instructions. The pump is designed for installation and service by properly trained personnel.



WARNING HAZARDOUS VOLTAGE:

DISCONNECT power cord before removing motor cover for service. **Electrical service by trained personnel only.**



WARNING HAZARDOUS PRESSURE/CHEMICAL EXPOSURE



Use caution and bleed off all resident system pressure prior to attempting service or installation.



Use caution when disconnecting discharge line from pump. Discharge may be under pressure. Discharge line may contain chemical.



WARNING RISK OF CHEMICAL EXPOSURE:

Potential for chemical burns, fire, explosion, personal injury, or property damage. To reduce risk of exposure, the use of proper personal protective equipment is mandatory.

TOOL LIST AND CLEANING SUPPLIES

- #2 Phillips head screwdriver
- Flat head screwdriver
- 3/8" open end wrench (to change index pin lifter)
- AquaShield™
- Fantastik® or similar (non-citrus) all purpose cleaner
- Needle-nose pliers
- Utility knife



CLASSIC SERIES SINGLE HEAD ADJUSTABLE PUMP

THREE BASIC SUBASSEMBLIES

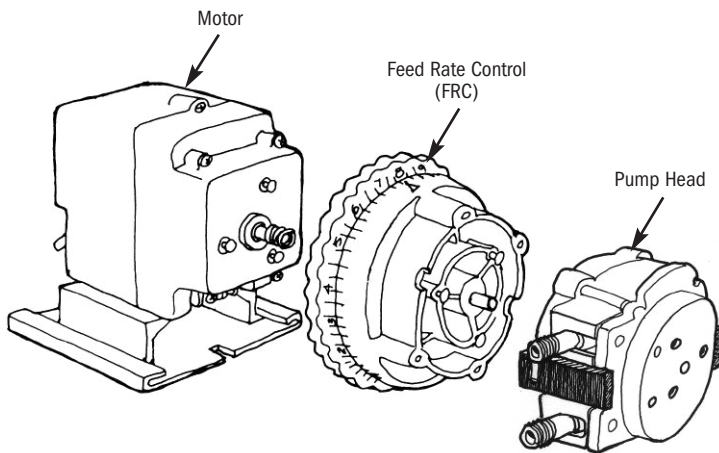

Use subassemblies in field for quick replacement.

INSTALLATION DIAGRAM FOR SINGLE HEAD PUMP

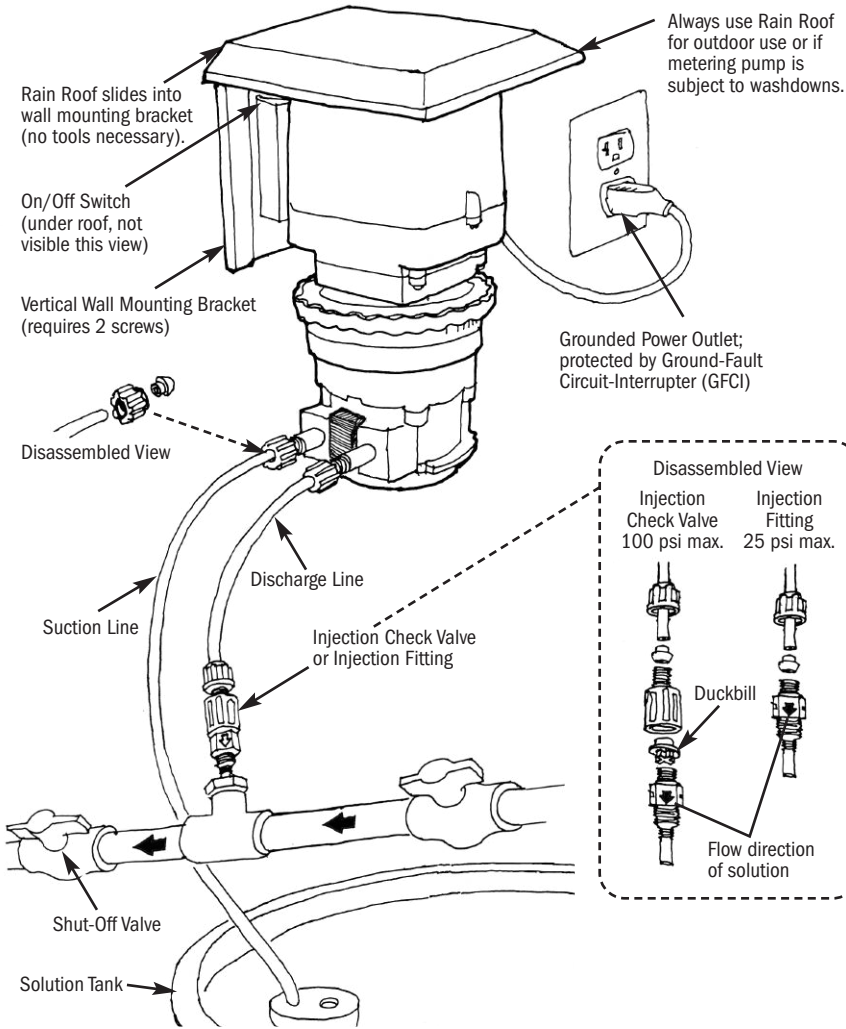

Optional Flow Indicator, to confirm solution is pumping.

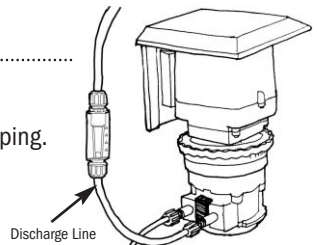

VERTICAL INSTALLATION

Mount the pump vertically and use the spill recovery to drain chemical back to the tank in the event of tube failure. This will help prevent chemical from collecting in the tube housing and reduces spillage on the floor.

The pump motor is ventilated and water intrusion can cause motor damage. A rain roof is recommended for outdoor and wet environments.

Spill Recovery Set-up

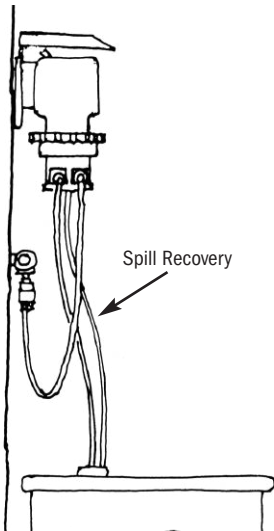

Vertical Mount with Rain Roof

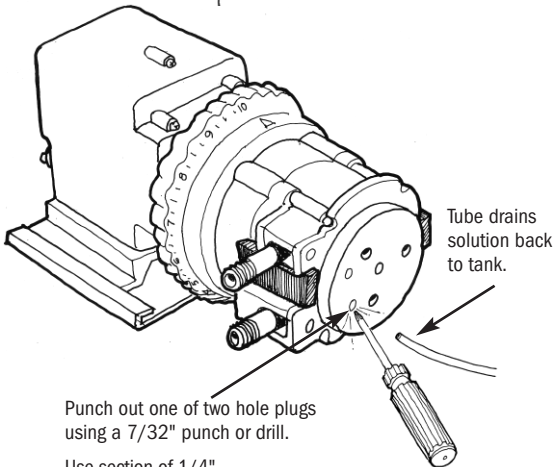
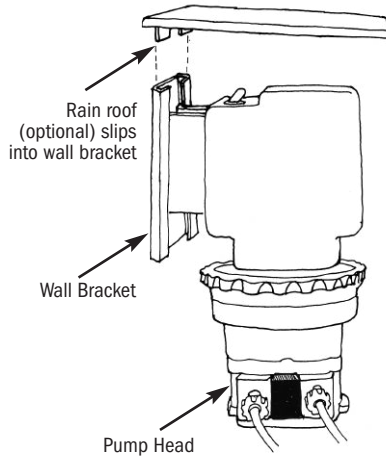

Punch out one of two hole plugs using a 7/32" punch or drill.

Use section of 1/4" suction/discharge tubing and insert in hole.

SUCTION AND DISCHARGE LINES

The suction line should be 3" from the tank bottom to prevent picking up sediment which can cause blockage in the check valve, duckbill and discharge line.

Allow slack in both the suction and the discharge lines so the pump tube fittings can flex. The slack prevents stress on the pump tube and fittings to help reduce the chance for breakage and leaks.

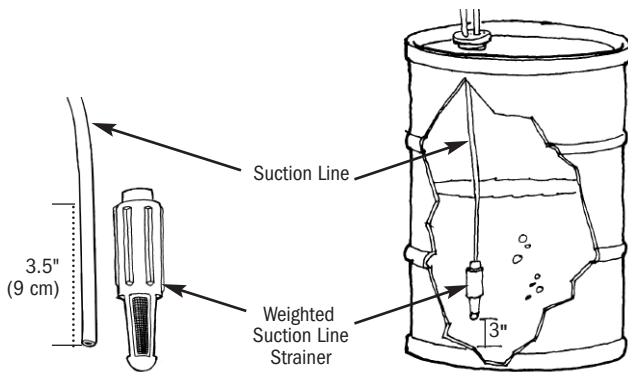

The suction line should not be inserted to the bottom of the weighted strainer. If the suction line becomes flush with the nose of the strainer, the pump may not prime due to blockage.



Use Stenner UV black suction and discharge tubing, rain roof and UV gray tank for outdoor applications.

COMPRESSION SEAL

The suction and discharge lines are installed to the pump tube fittings with a compression type seal consisting of the connecting nut and ferrule. The beveled end of the ferrule should face the tube fitting and the suction and discharge lines should bottom into the tube fitting.

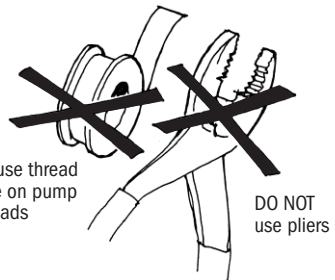
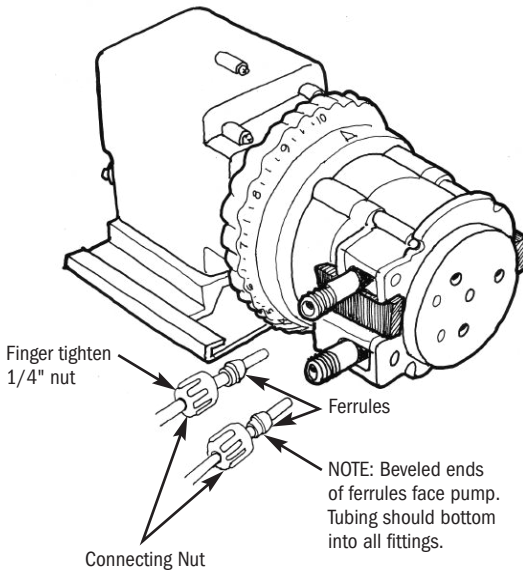

For 3/8" connections only. While stabilizing the tube fitting, attach female end of adapter to the tube fitting(s) (ferrule inside). Slide line through 3/8" connecting nut and finger tighten to male end of adapter. If leak occurs, gradually tighten the 3/8" connecting nut as required.

RIVET AND SLOT IDENTIFICATION

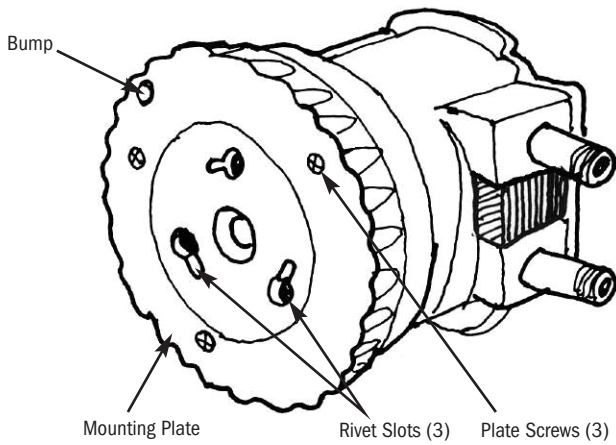
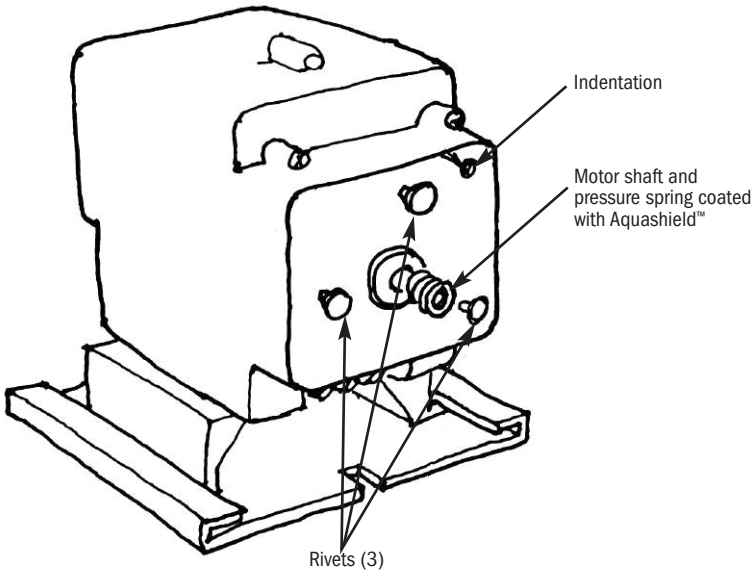

The pressure spring is not used with the fixed output pump.

SEPARATING SUBASSEMBLIES

1. Turn the pump off and unplug the power cord.
2. Hold the feed rate control section and turn the pump head clockwise until it stops.
3. Pull the pump head straight out.
4. Hold the motor assembly, grasp the feed rate control section and turn clockwise until it stops, and pull it straight out.

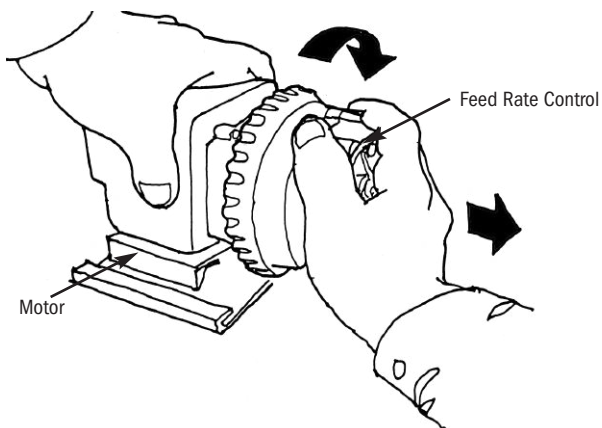
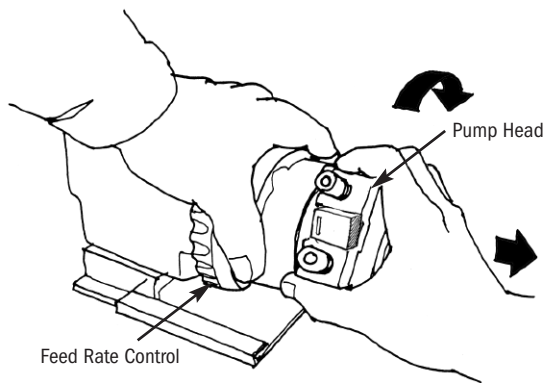

RECONNECTING FEED RATE TO MOTOR

1. Before reconnecting the feed rate control to the motor, confirm pressure spring (adjustable model only) is in place and place feed rate control on the shaft.
2. Turn the feed rate control counter-clockwise to line up the flat side of the motor shaft (d shaft) with the flat side of the brass spider in the feed rate control and push towards the motor.
3. Push and turn the feed rate control until the rivets on the gear case are inside the rivet holes on the feed rate.
4. Turn counter-clockwise until it locks into place and the bump on the feed rate mounting plate fits into the indentation in the gear case cover. The arrow on the feed rate control should be on top.

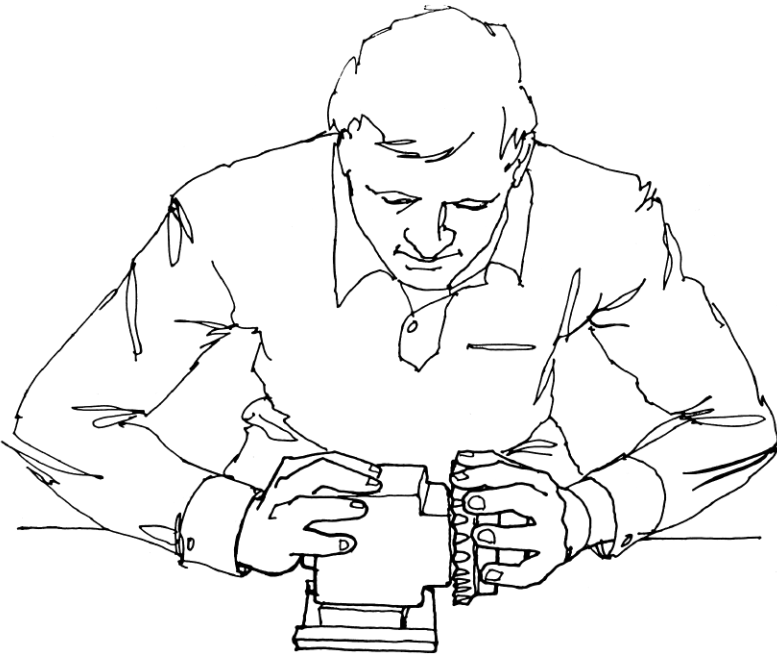

To reconnect the pump head to the feed rate control refer to *Pump Head Replacement* instructions page 33.

PUMP TUBE BASICS

The tube is the workhorse of the pump. It is perishable and will eventually stop functioning from natural wear or when it reaches the end of its service life. Indications of the end of service life are:

- Tube leaks
- Tube is fatigued causing a reduction or lack of output

The pump tube service life can be reduced by conditions of the application or the installation. These conditions are:

- Calcium or mineral deposits
- Sediment blockages
- Chemical incompatibility
- Corrosion
- Improper handling

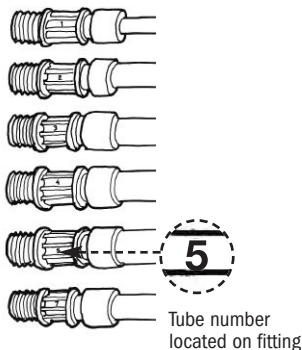

PUMP TUBE PRESSURE RATING

| PUMP TUBE | 25 psi (1.7 bar) max. | 100 psi (6.9 bar) max. Check valve required |
|-----------|-----------------------|--|
| #1 | ✓ | ✓ |
| #2 | ✓ | ✓ |
| #3 | ✓ | |
| #4 | ✓ | |
| #5 | ✓ | |
| #7* | | ✓ |

* Classic Single Head ONLY



For maximum pump tube life, always identify the reasons for the failure and correct the problem before a new tube is installed.

VISUAL REFERENCE

A diamond pattern that forms where the tube presses against the tube housing indicates excessive back pressure. Excessive back pressure can be caused by any blockage, a clogged duckbill or when the system pressure exceeds the pump tube pressure rating. An oval pattern indicates worn rollers and/or the pump tube has reached the end of its service life. Pump tubes can rupture without either pattern apparent.

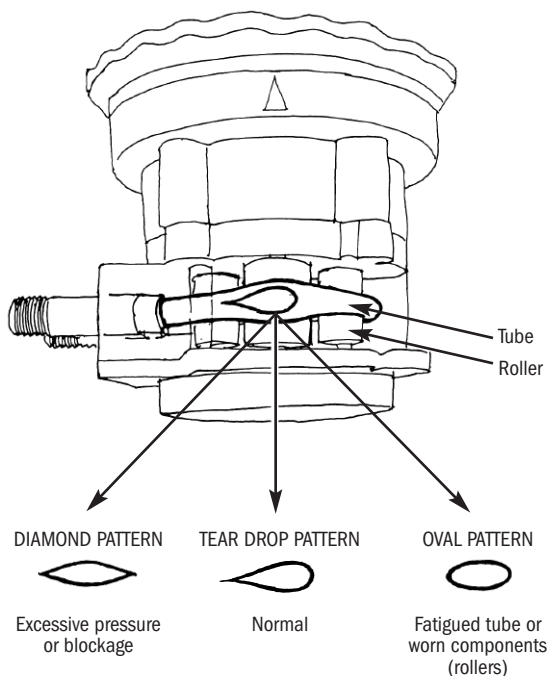

The most common tube problems are from a lack of routine maintenance. Always establish an application specific maintenance schedule.

CONDITIONS THAT REDUCE TUBE LIFE

IMPROPER TUBE HANDLING

- Not following factory tube replacement instructions.
- Storing tubes in high ambient temperatures or long term exposure to direct sunlight weakens tube material.
- Prior to installation, pre-stretching, lubricating the tube and/or roller assembly or pinching during installation, compromises the tube material.
- Excessive pulling of the tube fitting, during installation, can result in compromising the material. Allow the pump to run the roller assembly in its collapsed position for approximately two minutes to relax the tube as indicated in the tube replacement instructions.
- Using pliers to center or secure connections can damage ferrules. The connecting nut must be finger tightened only.
- Using thread seal tape prevents ferrules from seating properly into tube fitting and can cause leaks.
- Not allowing enough slack in the suction and discharge lines so the tube fittings can flex puts stress on the tube and fittings.



DO NOT use thread seal tape or pliers on pump tube threads.



CONDITIONS THAT REDUCE TUBE LIFE continued

CRACKED PUMP HEAD

The tube housing and latches can crack from wear, long term chemical exposure or due to solution incompatibility with the housing material (refer to *Chemical Resistance Guide*).

SEIZED ROLLERS IN THE ROLLER ASSEMBLY

Corrosive chemicals that collect on the roller bushings, as a result of atmosphere or tube failure, can result in seizing the rollers.

Corrective Action

1. Confirm chemical compatibility with housing and pump tube material.
2. Review factory recommended vertical pump installation.
3. In the event of tube rupture, rinse the chemical residue from the housing and roller assembly with factory recommended cleaners.
4. If tube housing is cracked, replace.

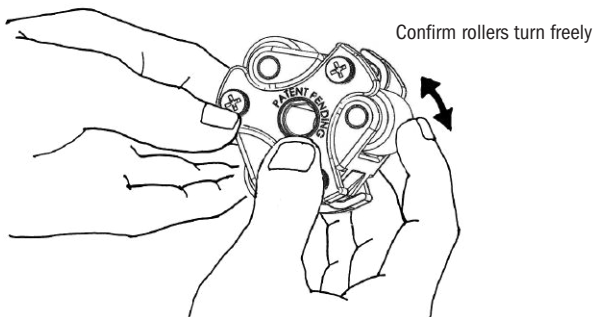

Normal roller wear can cause a lack of output as a result of the rollers' inability to fully squeeze the tube.

CONDITIONS THAT REDUCE TUBE LIFE continued

EXCESSIVE BACK PRESSURE AT THE POINT OF INJECTION

Calcium or mineral deposits in the injection fitting section of the check valve can cause blockage or restriction creating back pressure that exceeds the pump tube pressure rating.

Corrective Action

1. Insert a round shank screwdriver through injection fitting into the pipe to locate or break up accumulated deposits. If screwdriver can't be inserted, drill the deposit out of the injection fitting. Do not drill through the opposite pipe wall.
2. Replace duckbill.

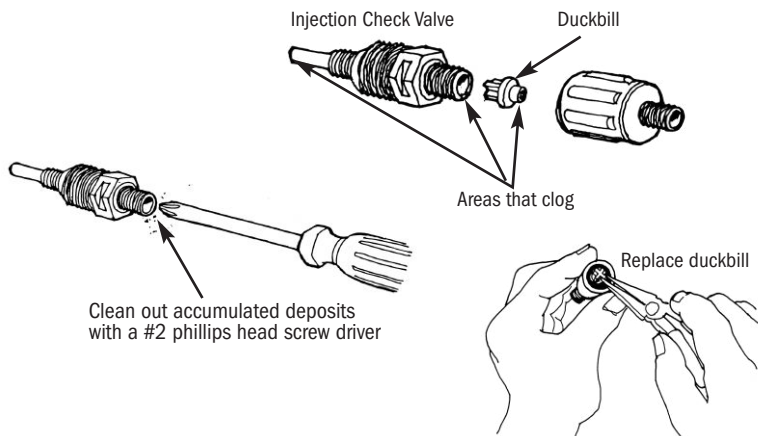

EXCESSIVE BACK PRESSURE AT THE POINT OF INJECTION

Insoluble sediments or particulates drawn through the suction line from the bottom of the tank can cause blockage or restriction in the check valve duckbill. These solids and excessive pressure can damage the pump tube.

Corrective Action

1. Replace suction and discharge tubing and clean sediment from tank bottom.
2. Position weighted strainer 3" from tank bottom.
3. Replace duckbill.



At every tube change, trim approximately 1" off the end of both the suction and discharge lines before installing new ferrules. Replace duckbill (100 psi maximum applications) and ferrules with every new tube.

CONDITIONS THAT REDUCE TUBE LIFE continued

SPLIT ALONG SIDE OF THE TUBE

The tube rubbing against the edge of the tube housing can cause the side to split.

Corrective Action

Always follow the factory's tube replacement instructions which include centering the tube on the rollers.

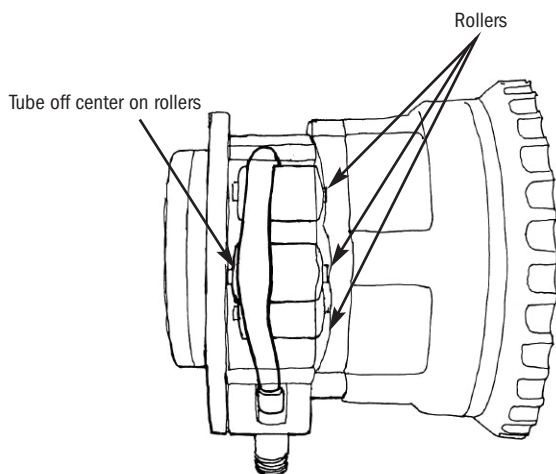

The tube will not center if it twists during installation or if the rollers are worn. The tube can also twist if the connections are over-tightened; finger tighten only.



Refer to the Trouble Shooting guide in the *Classic Series Installation Manual* for more pump tube and pump head conditions and solutions.

IMPORTANT TUBE INFORMATION

- Always follow factory tube replacement and centering instructions.
- Schedule a tube replacement at regular intervals according to the needs of the specific application.
- A used tube will have stretched approximately 3/4" and the new tube will appear to be stiff and short. Allow the pump to run the roller assembly in its collapsed position for approximately two minutes to relax the tube as indicated in the tube replacement instructions.
- Replace ferrules with every tube change, ferrules are the seal between the tube fitting and the connecting nut.
- Only finger tighten the nut and ferrule. Over-tightening may result in a twisted tube, damaged fittings, crushed ferrules and air pick-up.
NOTE: A twisted tube will not center and can decrease tube life.
- For 100 psi maximum applications, inspecting and replacing the duckbill at every tube change is recommended.
- Santoprene® pump tubes are not compatible with petroleum or oil-based products. Refer to the Chemical Resistance Chart in the *Catalog* for compatibility or call the factory.
- DO NOT allow tube fittings to turn inside the pump housing when connecting suction and discharge tubing. Tube will be forced off center towards cover and can wear a groove in the tube, leading to leaks.



For maximum tube life, always identify the reasons for the failure and correct the problem before a new tube is installed.

TUBE REPLACEMENT

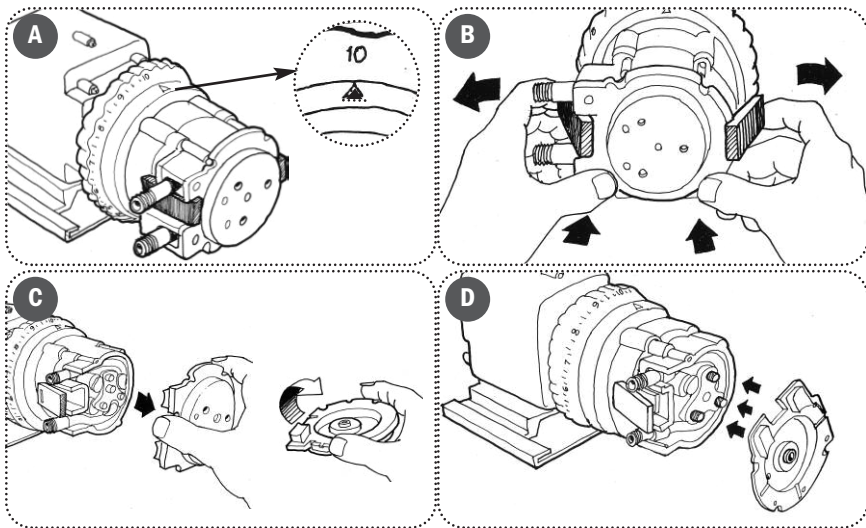

PREPARATION

1. Follow all safety precautions prior to tube replacement.
2. Prior to service, pump water or a compatible buffer solution through the pump and suction and discharge lines to remove chemical and avoid contact.

REMOVE THE PUMP TUBE

1. Turn the pump off and unplug the power cord. On the adjustable model, ensure that the feed rate control is set to 10. **Figure A**
 2. Depressurize and disconnect the suction and discharge lines.
 3. Open the back and front of the latches on both sides of the head. Carefully fold latches back to prevent contact with the cover. **Figure B**
For CE pump only: Remove the safety screw on cover.
 4. Remove the tube housing cover and flip to use as a tool in the next step. **Figure C**
 5. Align the center of the inverted cover with the center of the roller assembly so that the three holes on the face of the cover align with the three knurled lugs on the roller assembly. Position the cover feet near the tube fittings. **Figure D**
- NOTE: The roller assembly needs to be collapsed to remove the tube.

TUBE REPLACEMENT continued

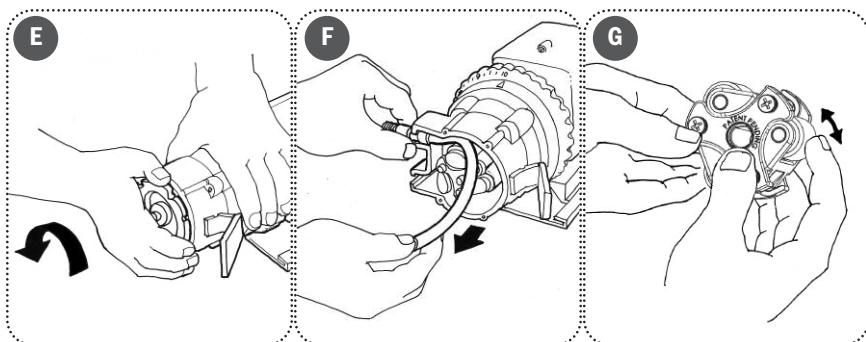

6. On the adjustable pump, hold the feed rate control securely. On the fixed output pump hold the pump securely. Use the tube housing cover as a wrench and quickly (snap) rotate the cover counter-clockwise to collapse the roller assembly. The tube will no longer be pressed against the tube housing wall. **Figure E**
NOTE: Counter-clockwise is viewed from facing the head of the pump.
7. Remove and discard the pump tube. **Figure F**
8. Remove the roller assembly, and the tube housing. On the adjustable pump also remove the shaft. Set them aside to reinstall later.
9. Use a non-citrus all-purpose cleaner to clean chemical residue from the tube housing, roller assembly and cover.
10. Check the housing, cover and roller assembly for cracks and replace if cracked.
11. Ensure the rollers turn freely. Replace the roller assembly if the rollers are seized or worn or if there is a reduction or lack of output from the pump. **Figure G**
12. Reinstall the clean tube housing. On an adjustable pump, also install the shaft into the feed rate control.
13. Apply AquaShield™ to the shaft tip.
14. Install roller assembly.



Tube replacement instructions for pumps manufactured before May 2011 are found on the website in the Downloads section.

TUBE REPLACEMENT continued

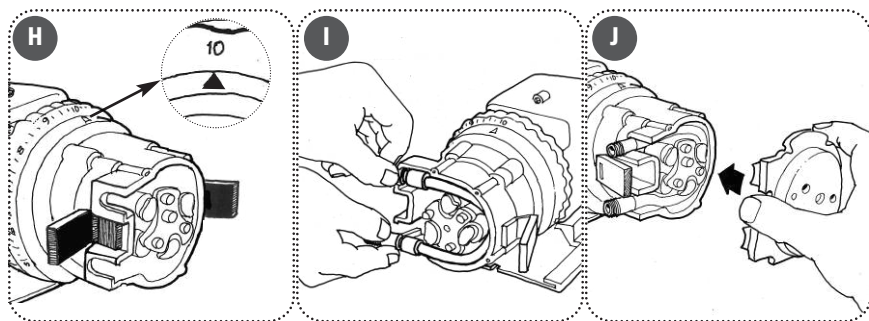

INSTALL TUBE

IMPORTANT! DO NOT LUBRICATE PUMP TUBE OR ROLLER ASSEMBLY.

1. Ensure the power to the pump is off and the power cord is unplugged. On the adjustable model, ensure that the feed rate control is set to 10. **Figure H**
2. Place the new tube in the pump head; use your fingers to center it over the rollers. **Figure I**
3. Place the tube housing cover on the tube housing, affix the front latches to the cover lip and then press the latches back to secure. Be sure the cover is seated with the sleeve bearing on the shaft and is flush with housing, before latching. **Figure J**



Identify the cause of tube failure prior to installing a new tube.



A used tube will have stretched approximately 3/4" and the new tube will appear to be stiff and short. Follow directions to allow rollers to stretch tube into place.

TUBE REPLACEMENT continued

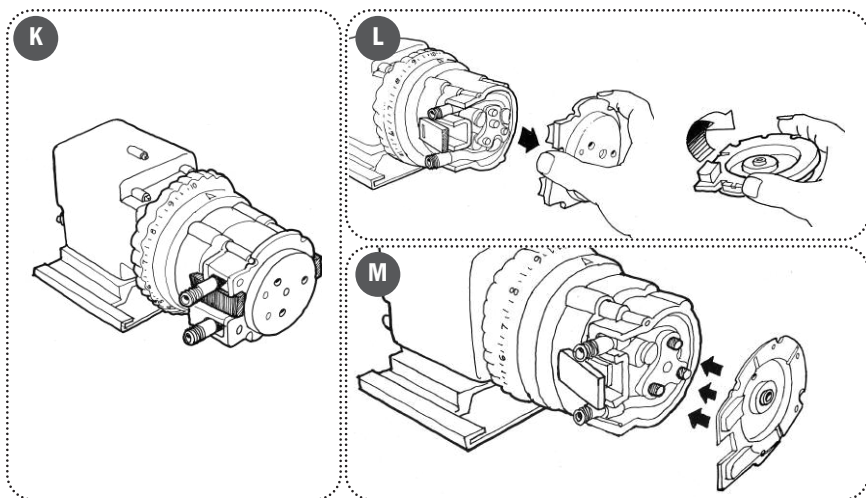

INSTALL TUBE continued

4. With the cover latched, plug the pump in and turn the power on. Allow the pump to run the roller assembly in its collapsed position for approximately two minutes to relax the tube. **Figure K**
5. Turn the pump off and unplug the power cord.
6. Remove the tube housing cover and flip to use as a tool in the next step. **Figure L**
7. Align the center of the inverted cover with the center of the roller assembly so that the three holes on the face of the cover align with the three knurled lugs on the roller assembly. Position the cover feet near the bottom. **Figure M**

NOTE: The roller assembly needs to be expanded so the tube is pressed against the tube housing wall.

TUBE REPLACEMENT continued

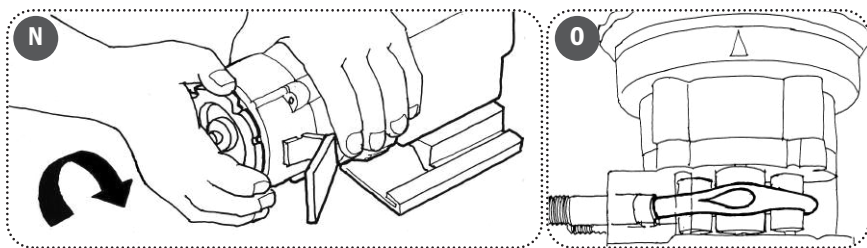

EXPAND THE ROLLER ASSEMBLY - ADJUSTABLE MODEL

8. Expand roller assembly

- Hold the feed rate control securely, use the cover as a wrench and quickly (snap) rotate the roller assembly clockwise to expand the roller assembly. The tube will be pressed against the tube housing wall. **Figure N & O**
Proceed to step 9 on page 29.

NOTE: Clockwise is viewed from facing the head of the pump.

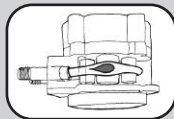
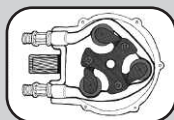

Before turning pump on, confirm roller assembly is expanded and tube is pressed against housing wall.

CAUTION: Use care when expanding roller assembly, excessive force can crack the hub and lead to failure of the roller assembly.



At every tube change, trim approximately 1" off the end of both the suction and discharge lines before installing new ferrules. Replace duckbill (100 psi maximum applications) and ferrules with every new tube.

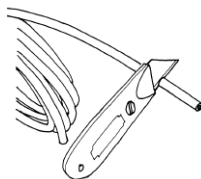

TUBE REPLACEMENT continued

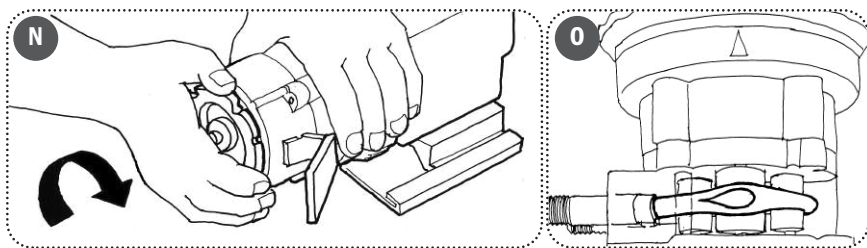

EXPAND THE ROLLER ASSEMBLY

– FIXED OUTPUT MODEL (Manufactured before 4/29/11)

8. Expand roller assembly

 **WARNING** ONLY THE STENNER FAN BRAKE TOOL SHOULD BE USED FOR THIS STEP.

- a. Insert the fan brake tool into the vent in the rear of the motor housing. Refer to the figures below.

NOTE: The fixed output pump doesn't have a clutch so the fan brake keeps the shaft from rotating when expanding the roller assembly.

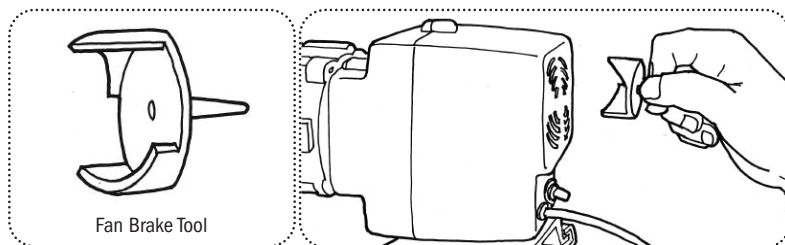

Fan Brake Tool

- b. Holding the pump securely, use the cover as a wrench and quickly (snap) rotate the roller assembly clockwise to expand the roller assembly. The tube will be pressed against the tube housing wall. **Figure N & O**
NOTE: Clockwise is viewed from facing the head of the pump.
- c. Remove the fan brake tool. Proceed to step 9 on page 29.

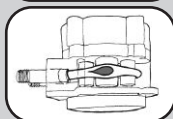
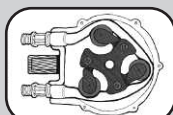

Before turning pump on, confirm roller assembly is expanded and tube is pressed against housing wall.

CAUTION: Use care when expanding roller assembly, excessive force can crack the hub and lead to failure of the roller assembly.

TUBE REPLACEMENT continued

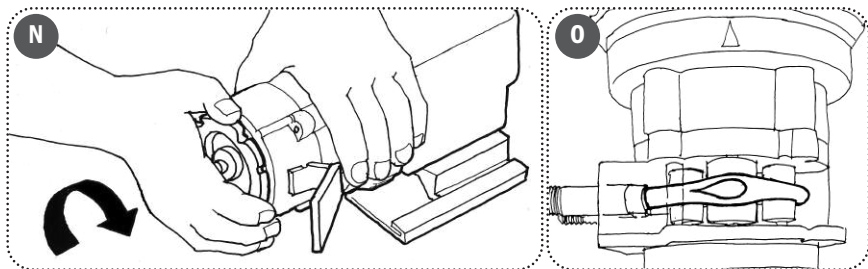

EXPAND THE ROLLER ASSEMBLY

– FIXED OUTPUT MODEL (Motor vent with key slot, manufactured after 4/29/11)

8. Expand roller assembly

- a. Slide one latch out to remove it from the tube housing. Insert the latch end into the key slot in the vent in the rear of the motor housing. While pressing the latch into the rear of the motor, gently rotate the cover clockwise until it stops. Refer to the figures below.

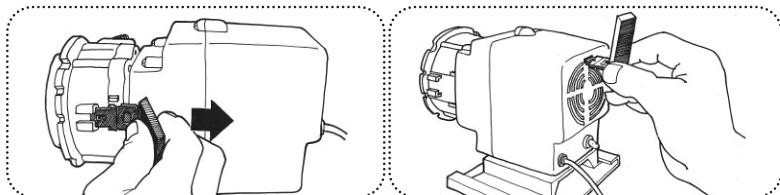

- b. Holding the pump securely, use the cover as a wrench and quickly (snap) rotate the roller assembly clockwise to expand the roller assembly. The tube will be pressed against the tube housing wall. **Figure N & O.**

NOTE: Clockwise is viewed from facing the head of the pump.

- c. Remove the latch from the vent and re-attach it to the tube housing. Proceed to step 9 on page 29.

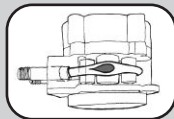
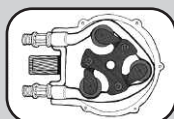

Before turning pump on, confirm roller assembly is expanded and tube is pressed against housing wall.

CAUTION: Use care when expanding roller assembly, excessive force can crack the hub and lead to failure of the roller assembly.

TUBE REPLACEMENT continued

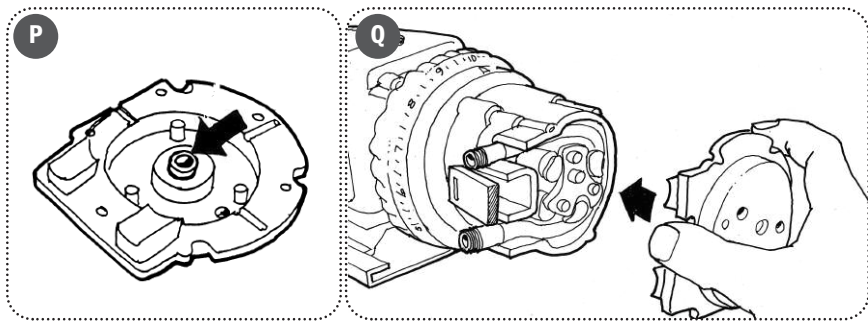

9. Apply a small amount of AquaShield™ to the cover bushing **ONLY**. **DO NOT** lubricate the pump tube. **Figure P**
10. Place the tube housing cover (feet first) on the tube housing, affix the front latches to the cover lip and then press the latches back to secure. Be sure the cover is seated with the sleeve bearing on the shaft and is flush with housing, before latching. **Figure Q**

TUBE REPLACEMENT continued

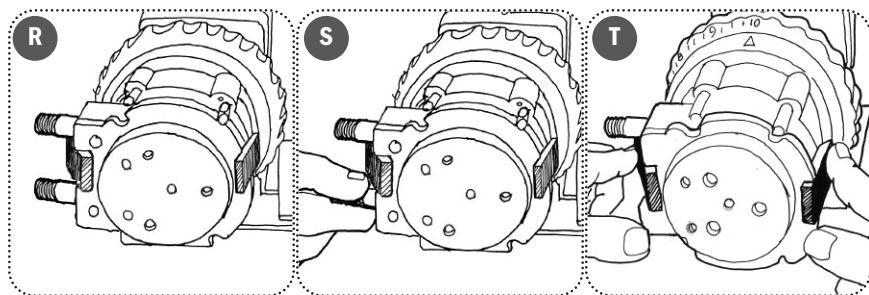

CENTER THE TUBE

1. Ensure the pump is off. Lift the latch located between the tube fittings, leaving the end of the latch engaged with the lip on the tube housing cover. Leave the latch on the opposite side engaged. **Figure R**
2. Plug the pump in and turn it on. Turn the tube fitting on the suction side not more than 1/8 of a turn in the direction tube must move. **Figure S**
3. DO NOT let go of fitting until tube rides approximately in center of rollers.
4. Turn the pump off, let go of the fitting, and secure the latch between the fittings. **Figure T**
For CE pump only: Reinstall the safety screw on the cover.
5. Inspect the suction and discharge lines, point of injection, and check valve duckbill for blockages. Clean and/or replace as required.
6. Reconnect the suction and discharge lines. DO NOT allow tube fittings to turn inside the pump housing.
7. Turn the pump on and verify operation.

PUMP HEAD REPLACEMENT

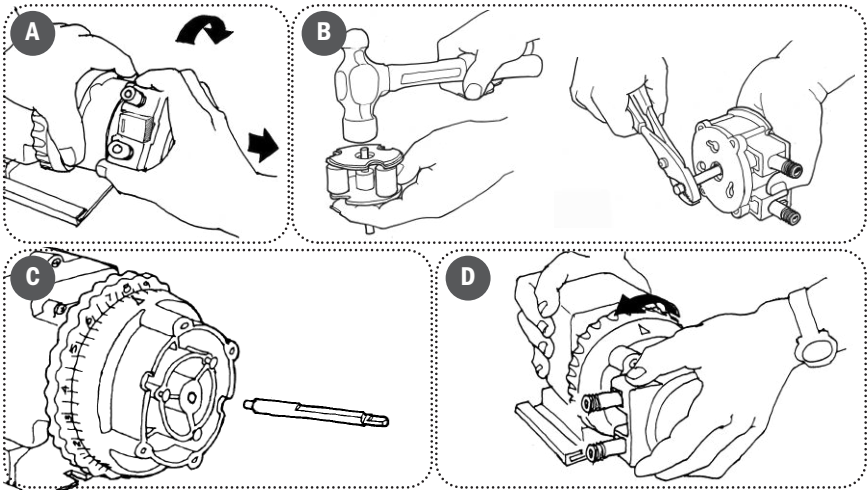

ADJUSTABLE MODEL

REMOVE PUMP HEAD & INSTALL QuickPro® PUMP HEAD

1. Turn off the pump and unplug the power cord.
 - a. To remove the pump head, hold the feed rate securely, grasp the head and turn it clockwise until it stops. **Figure A**
 - b. Remove the head by pulling it straight out from the pump. The main shaft will come out with the pump head.
 - c. Using a pair of pliers, grasp the main shaft and rock it back and forth (clockwise and counter-clockwise) while pulling it straight out of the pump head. Set aside the shaft to be reinstalled later. Discard the old tube, housing and cover. If the shaft will not come out, remove the cover from the pump head and use a hammer to tap the shaft from the front of the roller assembly to dislodge it. **Figure B**
 - d. Insert the shaft back into the feed rate control. **Figure C**
 - e. Put the new pump head onto the feed rate control and turn it counter-clockwise until the shaft falls into place.
2. Push the pump head in while turning it counter-clockwise. Line up the rivet holes on the pump head with the rivets on the feed rate control (adjustable pump) OR motor (fixed output pump). **Figure D**
3. Continue to push until the rivets are inside the holes.
4. Turn the pump head counter-clockwise to secure the rivets in the rivet slots, firmly attaching the pump head. Proceed to page 33.

PUMP HEAD REPLACEMENT continued

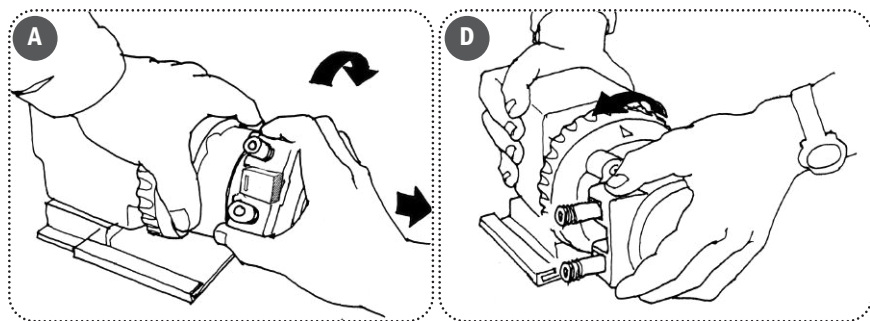

FIXED RATE MODEL

REMOVE PUMP HEAD & INSTALL QuickPro® PUMP HEAD

1. Turn off the pump and unplug the power cord.
 - a. To remove the pump head, hold the pump securely, grasp the head and turn it clockwise until it stops. **Figure A**
 - b. Remove the tube housing and roller assembly together by pulling it straight out from the pump. The shaft will remain in the pump. Discard the tube, housing and cover. If the housing and roller assembly are difficult to remove, insert a large, flat blade screwdriver between the pump body and the head. Gently pry the head forward, ensuring the rivets on the pump body remain disengaged from the tube housing.
 - c. Put the new pump head onto the motor and turn it counter-clockwise until the shaft falls into place. **Figure D**
2. Push the pump head in while turning it counter-clockwise. Line up the rivet holes on the pump head with the rivets on the feed rate control (adjustable pump) OR motor (fixed output pump). **Figure D**
3. Continue to push until the rivets are inside the holes.
4. Turn the pump head counter-clockwise to secure the rivets in the rivet slots, firmly attaching the pump head. Proceed to page 33.

PUMP HEAD REPLACEMENT continued

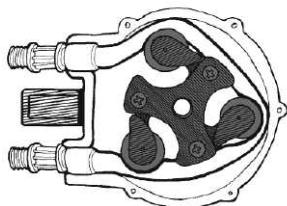

Expand the roller assembly

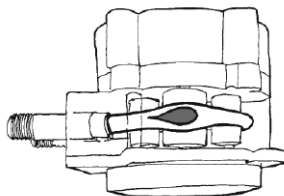

Tube is pressed against housing wall

EXPAND THE ROLLER ASSEMBLY

After the pump head has been replaced and before turning the pump on, confirm the roller assembly is expanded and the tube is pressed against the housing wall. Proceed to pages 26 to 29 in the **TUBE REPLACEMENT INSTRUCTIONS** to **EXPAND THE ROLLER ASSEMBLY** according to your model.

CENTER THE TUBE

Proceed to page 30 in the **TUBE REPLACEMENT INSTRUCTIONS** to **CENTER THE TUBE**.

FEED RATE CONTROL (FRC)

The feed rate control adjusts the output by utilizing a cam and spring loaded lifter system to control the rotation of the roller assembly according to the setting on the dial ring.

Inside the FRC is a brass spider assembly that consists of a pin with carbide tip and spring inside the holder attached to a lifter.

When the pump is on, the spider assembly rotates. When the lifter drops into the FRC channel, the pin engages the index plate rotating the roller assembly creating the pumping action.

When the lifter rides on the cam, the pin is lifted inside the holder. The roller assembly does not rotate, resulting in no pumping action.

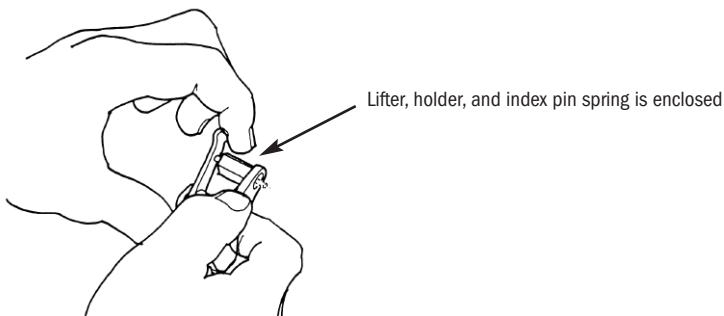
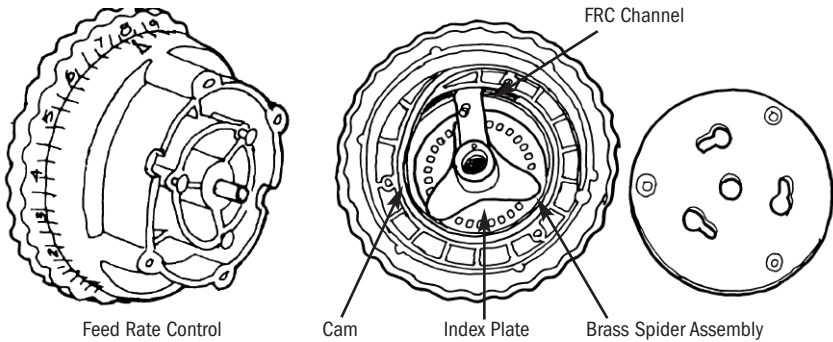

Index pin retracts when lifted.

FEED RATE CONTROL WEAR

Indication of wear is apparent when the feed rate control makes a skipping or ratcheting sound. The pump output is less than the desired setting.

GROOVE IN CAM

More cam is exposed to the rotation of the lifter at lower dial ring settings leading to cam wear and causing index malfunctioning. Higher settings will reduce cam wear. Inspect and replace cam as needed.



WORN LIFTER

If the lifter arm wears and flattens it may not fully lift the pin out of the index plate. The pin will make a ratcheting sound from dragging across the plate. The feed rate control will index inconsistently at different settings. Replace the lifter as needed.

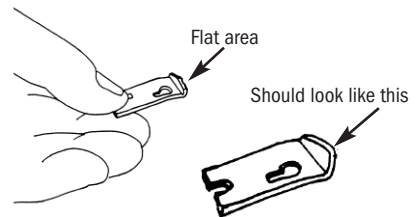

WORN INDEX PLATE

A worn cam or lifter can cause the index pin to drag across the index plate and elongate the holes. The pin will skip across the holes and cause index malfunction. The plate can be flipped to use the other side, or it may be replaced. Remember to grease with AquaShield™.

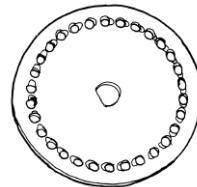

Index plate with elongated holes

Corrective Action

To reduce wear on the feed rate parts, specify the pump closest to its maximum output capacity within the needs of the application. Check the lifter, cam and index plate during scheduled maintenance.

FEED RATE CONTROL WEAR^{continued}

SEIZED INDEX PIN AND/OR LIFTER ASSEMBLY

Water or chemical intrusion will corrode the pin and lifter causing them to seize; the feed rate will malfunction.

Corrective Action

- 1.** Replace the index pin and/or lifter assembly as needed.
- 2.** Review the factory recommended vertical installation.
- 3.** Schedule a pump tube replacement at regular intervals according to the specific application. For 100 psi maximum applications replace the duckbill at every tube change.

FRC PARTS REPLACEMENT

1. Remove and set aside:
 - Three screws
 - Feed rate mounting plate
 - Dial ring (observe installed cam)
 - Brass spider assembly
 - Index plate
2. If required, remove index pin assembly by unscrewing with a 3/8" wrench and replace. When replacing the index pin holder, a small amount of thread locker should be used on the threads. Be sure the thread locker does not get on the index pin.
3. Flip worn index plate over OR install new index plate.
4. Clean out FRC channel before installing new cam.
5. Apply AquaShield™ to lubricate the cam's angled tip.
6. To install the cam, feed the angled cam tip into the FRC channel and keep the 90° end in the up position. Place thumb over the cam to guide as it is inserted in the channel.
7. Continue to feed the cam in the channel until there is approximately a 1/2" gap between the cam tip and the beginning of the channel.

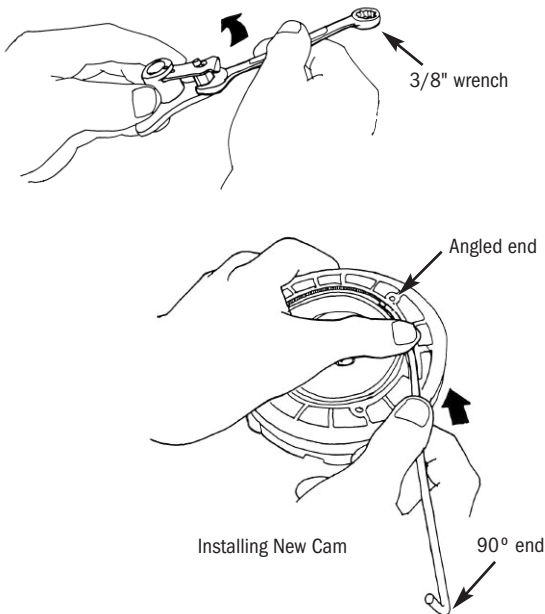

FRC PARTS REPLACEMENT continued

8. Apply AquaShield™ to the inside of the dial ring for easier turning.
9. Place dial ring boss onto the cam's 90° end.
10. While keeping the 90° end in the boss and the cam in the FRC channel, in a clockwise motion, place the dial ring onto the FRC housing and snap into place.
11. Apply AquaShield™ to bottom of the FRC housing before placing index plate inside. Apply AquaShield™ to the top of the index plate.
12. Place the spider assembly on the index plate. The lifter tip should be positioned in the 1/2" gap in the FRC channel.
13. To secure mounting plate, align its arrow with the FRC housing arrow and install the three screws.

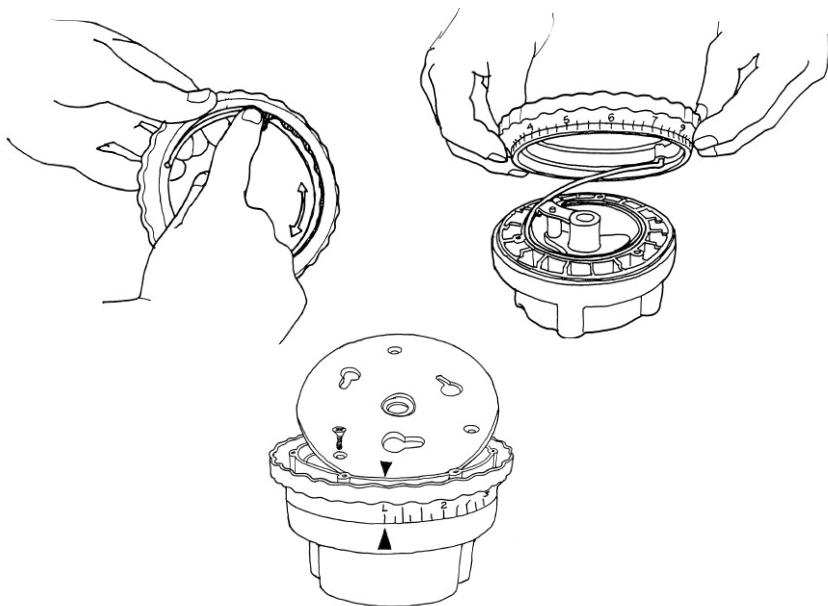

If the dial ring does not rotate from L to 10, the FRC mounting plate is in the wrong orientation.



The dial ring will be stiff or difficult to rotate if it lacks AquaShield™ or the screws are over tightened. If the screws are too loose, the dial ring can inadvertently be turned to setting 10 by the motor.

MOTOR

The motor has a cylindrical rotor with shaft that is encased within a magnetic coil. When power is applied to the coil, the rotor rotates. The rotor's directional rotation is determined by the orientation of the copper shaded poles on the coil. The helical end of the rotor engages the series of gears in the gear case.

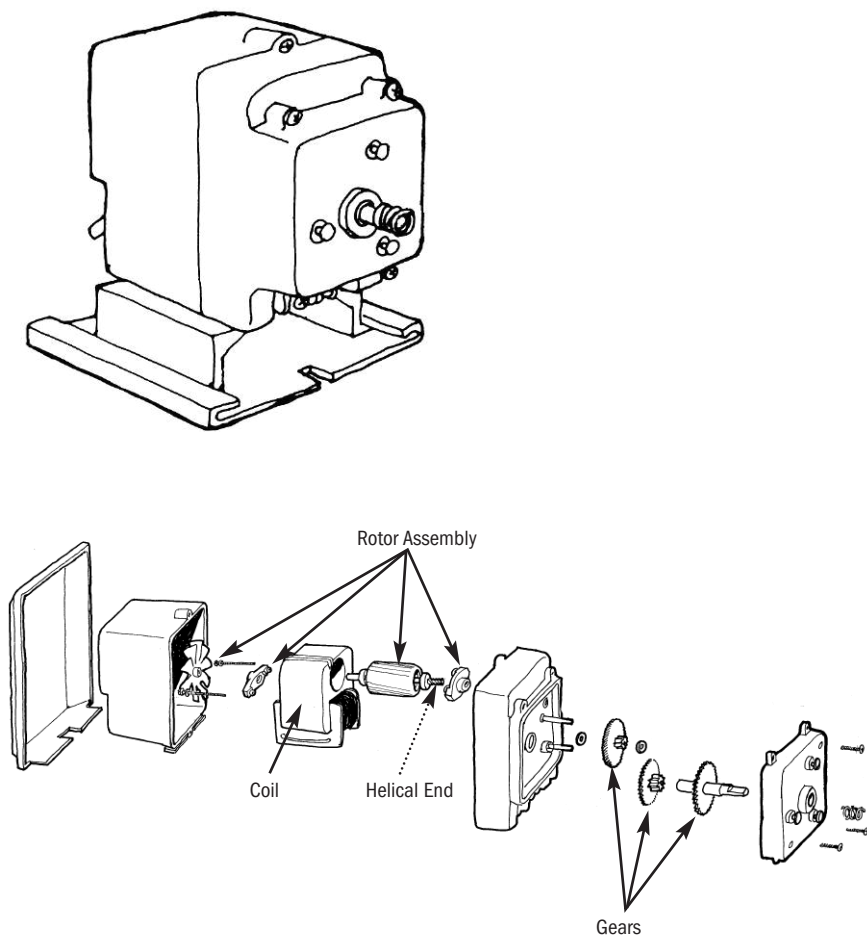

CAUSES OF MOTOR MALFUNCTION

LIQUID INTRUSION

The motor is fan cooled and needs proper ventilation while protecting it from water intrusion.

Corrective Action

Mount the single head pump vertically with pump head downward and use the rain roof in outdoor installations, in areas subject to wash downs, or in moist environments.

CHEMICAL VAPORS

The motor won't be able to rotate freely if the coil, rotor and bearing are rusted or corroded.

Corrective Action

1. Avoid mounting the pump over an open solution tank.
2. Review vertical installation.

INCORRECT VOLTAGE

The motor voltage must match power supply to avoid a burned coil.

Corrective Action

Use a volt meter for confirmation.

DAMAGED BEARING BRACKETS

Cracked or broken bearing bracket(s) result in rotor mis-alignment that can cause the rotor to bind to the magnetic coil that may be evident by a humming sound.

Corrective Action

1. Check the condition of the brackets and phenolic gear.
2. Replace parts as needed.



Refer to the Trouble Shooting guide in the *Classic Series Installation Manual* for motor conditions and solutions.

ROTOR ASSEMBLY REPLACEMENT

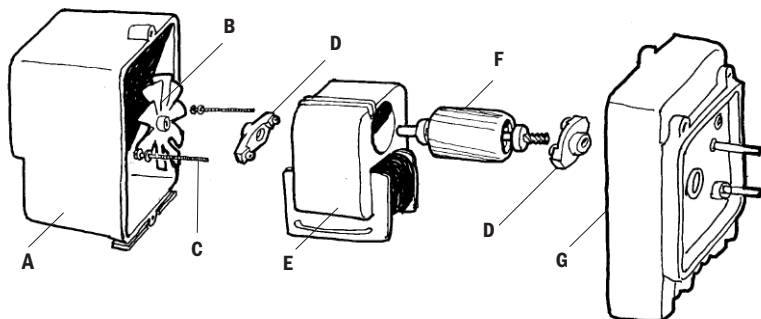

A rotor assembly includes **B, D & F**.

- Remove and set aside:
 - Two motor housing screws (not shown)
 - Motor housing **A**
 - Plastic fan **B** (discard old fan)
 - Two coil screws and lock washers **C**
 - Coil (keep wires connected) **E**
- Remove and discard the rotor **F** and two amber bearing brackets **D**.
- Press the new amber bearing bracket **D** onto the threaded brass inserts in the back of the gear case **G**. Make sure that the tolerance ring is in place inside the bracket **D**.
- Install the new rotor **F** by inserting the shaft (helical gear side) onto the amber bearing bracket **D**.
- Place the coil **E** (see Correct Coil Orientation) over the rotor **F** onto the bearing bracket **D**.
- Snap into place the second bearing bracket onto the rotor.
- Insert two coil screws with lock washers **C** and tighten. Be sure to hand start these screws to prevent cross threading.
- Starting at an angle, press fan **B** (with hub side down) onto the rotor shaft.
- Reinstall the two motor housing screws and tighten the self-tapping screws to secure the motor housing **A**.

Correct Coil Orientation

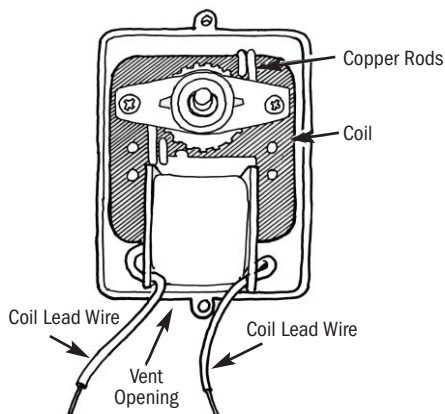

COIL REPLACEMENT

1. Disconnect power to pump.
2. Remove motor base. Remove two motor cover screws.
3. Invert the pump and use the pump head and feed rate control as a stand to work on the motor. See illustration.
4. Remove fan and set aside.

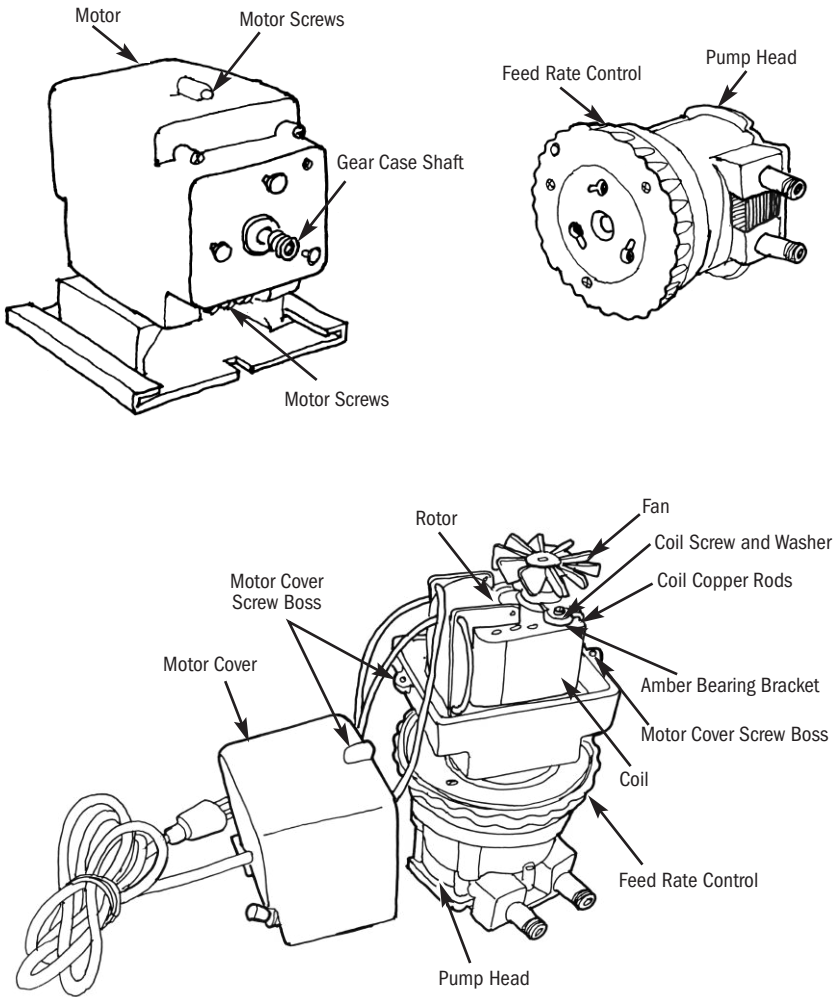

COIL REPLACEMENT continued

5. Disconnect ground wire (with eyelet) and set screw aside.
6. Cut the power cord and coil lead wires from motor cover at the wire nut (four cuts total). Set cover to the side.
7. Remove and set aside:
 - Two coil screws and washers from the rotor bracket
 - Plastic amber bearing bracket
8. Remove coil and discard.

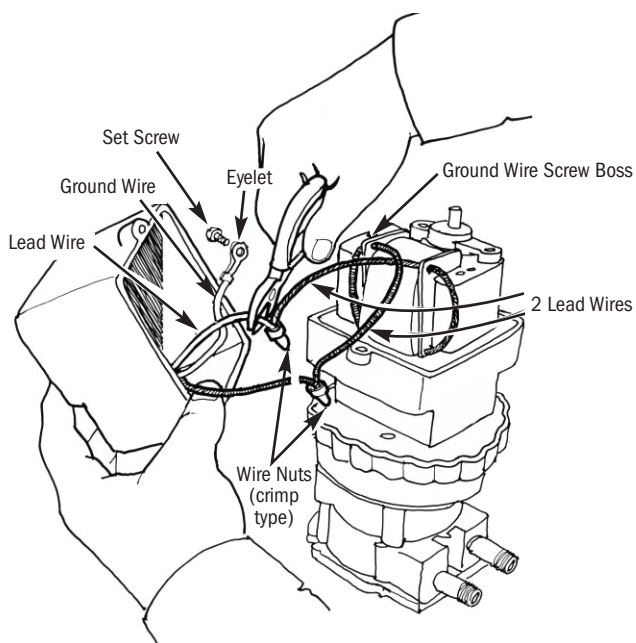

COIL REPLACEMENT continued

9. Install new coil over rotor on the remaining amber bracket. The correct orientation is with two copper rods in the upper right corner and the vent opening at the bottom of the gear case. Place bracket back on the rotor and securely seat into new coil. Install screws and washers and fasten bracket to coil. Be sure to hand start these screws to prevent cross threading.
10. With the metal band facing the bracket, press fan flush on rotor shaft.

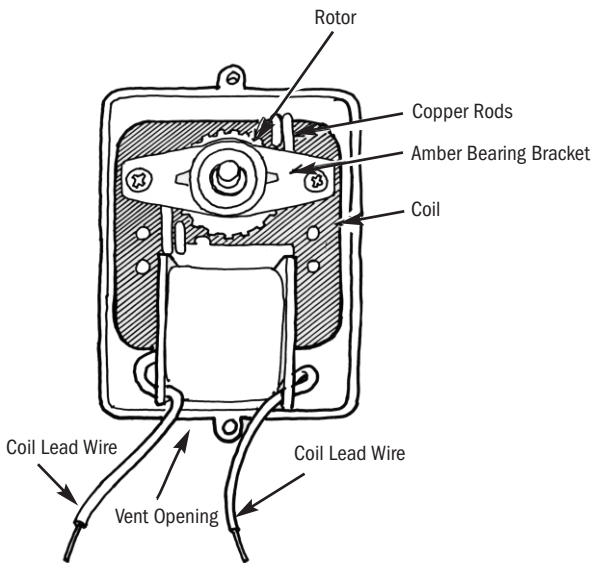

COIL REPLACEMENT continued

11. With wire strippers set at 16 gauge, strip approximately 1/2" from the power cord and on/off switch lead wires in the motor housing.
12. Secure ground wire (with eyelet) to motor coil.
13. Crimp the stripped lead wires to each of the new coil lead wires.
14. Tuck wire nuts into bottom of motor cover and secure cover back in place (before tightening, reverse cover screws to catch original threads).
15. Apply power to motor and test.

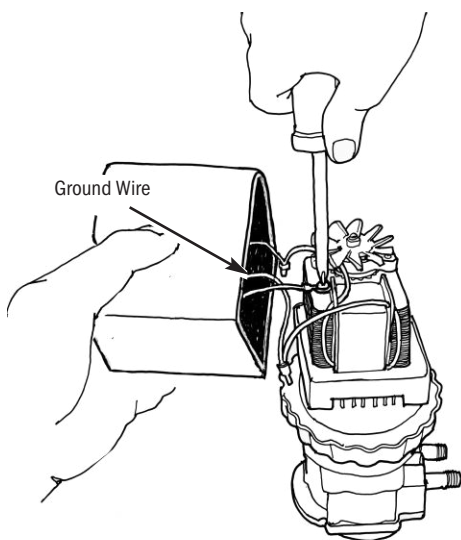
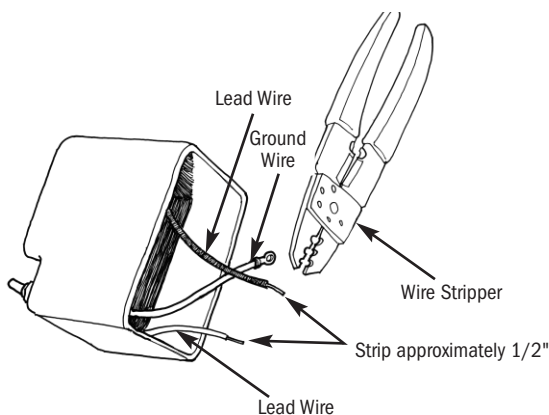

GEARS

Located in the gear case, the metal reduction gear and phenolic gear control the rpm of the feed rate and pump head. The 45 and 100 series delivers approximately 26 rpm and approximately 44 rpm for the 85 and 170 series. The motor shaft with gear drives the feed rate control.

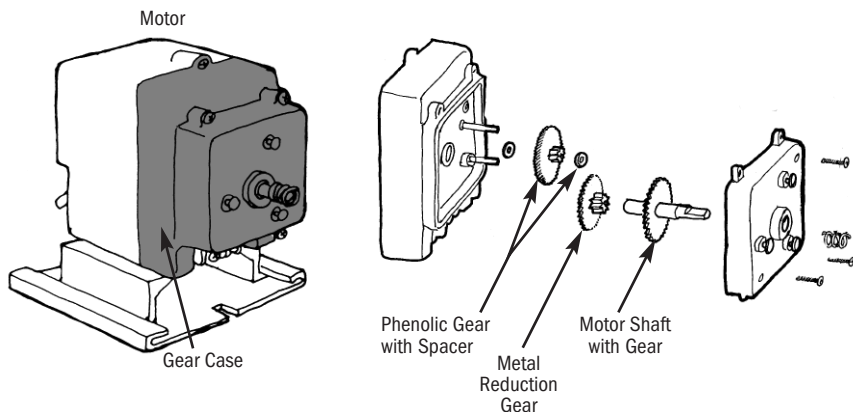

GEAR SET IDENTIFICATION

The illustrations show the diameters of the gears and pinions.

45 & 100 SERIES GEARS

Phenolic Gear

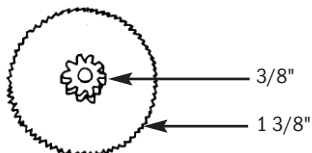

Metal Reduction Gear

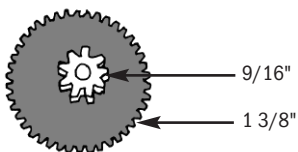

85 & 170 SERIES GEARS

Phenolic Gear

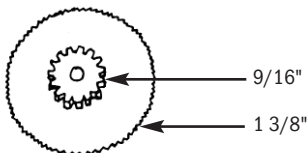

Metal Reduction Gear

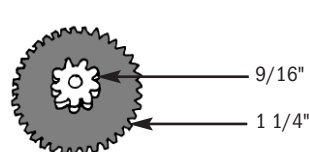

GEAR WEAR

Generally, gear failure can be caused by misalignment mainly due to the wear over the service life of the pump.

Check for the following conditions that can contribute to the phenolic gear stripping.

- Water or chemical intrusion
- Cracked bearing bracket
- Worn gear posts
- Worn gear case cover
- Rusted helical gear
- Insufficient lubrication

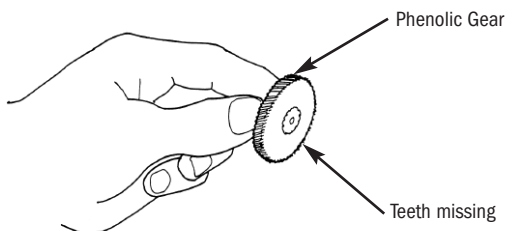

Corrective Action

1. Review the vertical installation that includes using a rain roof in outdoor applications or wet environments.
2. Replace gears that show visible wear or corrosion.
3. Replace gear posts that are worn, rusted or corroded.
4. Inspect the gear case and cover for cracks or corrosion and replace as needed.
5. Inspect the helical gear at the end of the rotor. Buff off the rotor if rusted or replace the rotor assembly.
6. Lubricate with AquaShield™.



Apply a generous amount of AquaShield™ to gear posts, pinions, gear rings and the main shaft with gear after doing service in the gear case.

GEAR REPLACEMENT

1. Remove four Phillips head screws from gear case cover.
2. Remove gear case cover.
3. Remove gears and inspect posts. To remove posts, grasp with pliers and pull straight out.
4. Wipe away old grease, check for rust or corrosion on the rotor shaft and remove with wire brush any visible rust or corrosion prior to replacing gears.
5. Install gear posts by tapping with rubber mallet until bottomed.
6. Apply AquaShield™ on new gear posts before installing gears.
7. Install phenolic gear and spacer.
8. Install metal reduction gear and motor shaft with gear.
9. Use remaining AquaShield™ on top of the three gears.
10. Re-attach gear case cover with four screws and tighten. Screws must be backed in to locate original threads before securing, to prevent stripping screw boss.

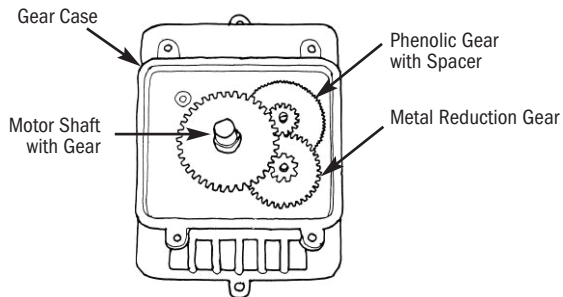
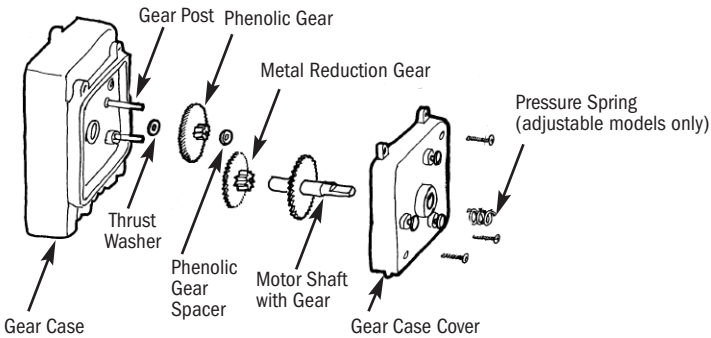

INSIDE COVER
NO PRINTING

STENNER PUMPS

STENNER PUMP COMPANY

3174 DeSalvo Road
Jacksonville, Florida 32246 USA

Phone: 904.641.1666

US Toll Free: 800.683.2378

Fax: 904.642.1012

sales@stenner.com

www.stenner.com

Hours of Operation (EST):

Mon.–Thu. 7:30 am–5:30 pm

Fri. 7:00 am–5:30 pm

 Assembled in the USA

© Stenner Pump Company
All Rights Reserved

Illustrations by David Stiles
www.stilesdesigns.com