

Installation & Instruction Manual

All Residential & Small System Models

(except EZ⁹⁵)

RadonAway

3 Saber Way | Ward Hill, MA 01835
radonaway.com

TABLE OF CONTENTS & FIGURES

1. PRE-INSTALLATION	3
1.1. Safety Matters.....	3
1.2. Water Flow Requirements.....	4
1.3. Unpacking and Locating System Components.....	5
1.3.1. Unpack All System Components.....	5
1.3.2. Locate All Components.....	5
1.4. Use Qualified Technicians.....	5
1.5. Full Water Test.....	5
2. INSTALLATION INSTRUCTIONS	6
2.1. System Location.....	7
2.2. Readyng the AIRRaider™ for Installation.....	7
2.3. Plumbing Hook-up.....	9
2.4. Electrical Hook-up.....	11
2.5. Vent Line Installation.....	16
2.6. Remote Air Intake.....	17
2.7. System Start-up.....	18
2.8. System Check.....	19
3. RETESTING	20
4. MAINTENANCE	20
4.1. Six Month Service (recommended).....	20
4.2. Annual Service (required).....	21
5. TROUBLE SHOOTING	22
LIMITED WARRANTY	23
APPENDICES	
A.1. Pump Specification, 433-S50 Systems, pump model 20DOMO5121+1.....	insert

Table of Figures

Figure 1 a,b,c - Typical Systems (433-S, 433, 321).....	6
Figure 2 - Pump & Bypass Assembly (433/321).....	7
Figure 3 - Installed System (433, 321).....	8
Figure 4 - Plumbing Installation (433-S50).....	9
Figure 5 - Plumbing Installation (433-S50X).....	10
Figure 6 - Wiring Diagram 433 115V/230V.....	12
Figure 7 - Wiring Diagram 433 S50/115V.....	13
Figure 8 - Wiring Diagram S50X/115V.....	14
Figure 9 - Wiring Diagram 321/115V.....	15
Figure 10 - Vent Line Connection.....	16
Figure 11 - Vent Line Installation (2 inch).....	16
Figure 12 - Vent Line Installation (3 inch).....	16
Figure 13 - Air Filter.....	17
Figure 14 - Air Intake Connection.....	17
Figure 15 - Installed AIRRaider™ (433-S50).....	18

1. Pre-Installation

The AIRaider™ Systems are diffused bubble aeration systems for the removal of radon and other VOC's from residential and municipal water supplies. This installation/operation manual is designed to guide professionals through the safe and proper installation of the AIRaider™ Systems.

Before beginning the installation of the AIRaider™ System, there are 5 items to be considered. They are:

1. Safety
2. Installation Site Requirements
3. Inspection of System Components
4. Necessity for Qualified Technicians
5. Knowledge of all Contaminants in the Water

1.1. Safety Matters

Safety is the most important step in the installation process. Never perform any step of the installation that you are not qualified to perform (i.e. Electrical or plumbing hook up). It is important that you read through the entire manual prior to beginning the installation. When performing the installation, work slowly and deliberately. Follow all instructions carefully and never take shortcuts. Our team of technicians is available to answer your questions at 800-355-0901.



WORK SAFELY!

1.2. Water Flow Requirements

The standard residential AIRraider™ Systems are designed for use with water flows up to 20 gallons per minute (GPM).* The system comes equipped with an outflow ball valve. If higher/ lower system outflow is needed, open/close the ball valve by the amount necessary to balance the system. The well pump output must produce at least 1 GPM more than the output of the AIRraider™ (i.e. well output = 8 GPM ; AIRraider™ outflow setting = 7 GPM) for proper system performance. If the well pump output is less than the system output the AIRraider™ will run dry and possible damage may occur. To prevent this from occurring the water flow rate must be determined before the system is installed.

**Some AIRraider™ Systems are not recommended for high flow residential properties. All repressurization systems (except for the AIRraider™ EZ⁹⁵, 433-S50 & 433-S50X) are sold separately. Proper repressurization system sizing is required to meet water flow needs. Consult manufacturer if assistance is needed for system selection.*

In order to determine available water flow rate the following is needed:

- Garden Hose
 - Five-Gallon Bucket
 - A Stop Watch or Watch with a Second Hand
- Or**
- A Water Flow Meter

Household water use must be discontinued during the following flow rate test.

Mid-Range Flow Rate Test:

1. Attach garden hose to the drain connection on the base of the Well Pressure Tank.
2. Open the drain valve and run water for 15 minutes.
3. After 15 minutes, check the pressure gauge on the well system. Adjust the drain valve (open or close) as needed to maintain the required running system pressure (constant pressure on gauge) with the well pump running continuously.
4. Run for 5 minutes while ensuring that the pressure is not fluctuating.
5. Run water from the hose into a five gallon bucket. Using a stop watch, time how many seconds it takes to fill the bucket (Z sec.).
6. Determine the GPM by dividing 60 seconds by the number of seconds it took to fill the bucket (Z sec.). Multiply the answer by 5 gallons. This gives you the GPM. $GPM = (60 / Z) \times 5$
7. Repeat steps 5 and 6 and average the 2 numbers. The answer is the well pump output in gallons per minute. It is recommended that this number be indelibly recorded in an obvious location, together with the date of test, as it will be required when setting the AIRraider™ System and may be required for future troubleshooting of the well pump system or the AIRraider™ System.

1.3. Unpacking and Locating System Components

1.3.1. Unpack All System Components

Remove all packing material and discard appropriately away from the work area.

1.3.2. Locate All Components

Check to ensure all components are intact and included in shipment.(See Figure 5 and 8)

Included component list (may vary with order):

- Tank Assembly with Solenoid Assembly
- Control Panel* and Float Switches
- Submersible Pump**
- Jet Pump and Bladder Tank Assembly***
- Brass – Bypass Assembly, Pump Brass, and Tank Brass****
- Installation Kit – Manual, Pressure Gauge, etc.

* Model 321 does not come equipped with a control panel

** Mounted internally on 433-S50 and 433-S75 Systems, not supplied with 433 and 321 Systems.

*** Pump packages are sold separately on 321 and 433 Systems, and will vary with the order. Bladder Tanks are sold separately.

**** Sold separately on 321 and 433 Systems. Standard systems are equipped for a ¾" plumbing connection. 1" plumbing connection is available on 433 Systems only (Not 433 433-S50 or 433-S75). Please specify plumbing connection requirements when ordering. Bypass Assembly is integral on 433-S50 Systems Only.

1.4. Use Qualified Technicians

A Licensed Plumber, Electrician, Contractor and/or Certified Water Treatment Specialist may be required to install the AIRRaider™ System in accordance with the installation instructions. All wiring must be performed in accordance with the National Fire Protection Association's (NFPA) National Electrical Code, Standard #70"-current edition for all commercial and industrial work. All wiring must be performed by a qualified and licensed electrician. Check your Local and State Code and Licensing requirements. Failure to follow the instructions may lead to poor system performance and/or possible system damage.

The Installation must comply with all applicable Local and State Codes and NFPA National Electrical Code, Standard #70!

1.5. Full Water Test

A full Water Sample Analysis must be performed to determine the quality of the water that requires treatment. In many water supplies, contaminants other than radon are present and may need to be pre-treated in order for the AIRRaider™ to work properly. The AIRRaider™ System is only effective for the removal of radon and some other VOC's. The Aeration Process employed by the AIRRaider™ System and other radon removal systems can worsen problems due to iron or manganese contaminants in the water supply. For optimal removal of radon or other VOC's, other contaminants such as iron, or manganese must be removed before the water supply enters the AIRRaider™ System.

Failure to remove other contaminants can reduce the effectiveness of the system and may result in system damage!

2. Installation Instructions

OVERVIEW

Now you are ready to begin the installation process. The eight steps to properly install the AIRRaider™ System are listed below. Read all components of each step prior to beginning the actual installation.

1. System Location
2. Readyng the System for Installation
3. Plumbing Hook-up
4. Electrical Hook-up
5. Vent Line Installation
6. Remote Air Intake Installation
7. System Start-up
8. System Check



SAFETY TIP: Do Not undertake any step for which you are Not Qualified.



433-S50



433 & 433-1



321

Figure 1 a,b,c
Typical System

(Repressurization Systems not shown, sold separately on 321, 433 and 433-1)

2.1. System Location

When selecting the location for the AIRraider™ System, five factors should be among those considered:

1. System Plumbing Hook-up. Find a location that will minimize the amount of plumbing necessary, this is typically in proximity to the well tank.
2. Electrical Hook-up. Keep in mind the need for accessibility to a 20 Amp dedicated 120VAC power supply or 30 Amp dedicated 230VAC for 230V 433 Systems.
3. Exhaust Line Venting. The location of the system must allow for outside venting of the system exhaust above the eave of the structure. The manufacturer requires that the exhaust pipe pitch back toward the system (see Section 2.6).
4. Remote Air Intake. If the system must be installed in an area with questionable air quality (i.e. furnace room, garage, crawl space) then ducting from the air intake to a remote location having good air quality may be required.
5. System Must Be Level. The system should not be located on a significant slope as this may impede system performance.

Place the system in the location acceptable to customer that maximizes the ease of installation. All Local and State codes as well as any applicable AARST, EPA and/or State Radon standards must be adhered to when locating the AIRraider™ (i.e. away from electrical panel, furnace, exits, etc.).

2.2. Readyng the AIRraider™ for Installation

For 433 and 321 systems (433 Illustrated). This section does not apply to Systems with integral pumps (433-S50 & 433-S50X Systems).

1. If using the Grundfos MQ3-45 Pump attach Mounting Bracket to wall as shown in Fig. 3 (page 8). Note bracket hole height is specific to the Grundfos MQ3-45. If using a different pump adjust bracket height as required to place pump suction pipe centerline at the system outlet centerline as specified in Fig. 3.

Note: Short horizontal pipe run from system outlet to pump inlet is optimal. If this pump location is impractical because of space constraints the pump may be located remotely at a higher location, but pump lift, pipe diameter, and equivalent pipe length must comply with limits specified in the pump installation instructions.

Do not mount pump lower than shown as removal of the pump for service may result in tank contents siphoning out onto the floor!

2. Install the Suction Check Valve provided with the Grundfos MQ3 Pump into the pump inlet as shown in the pump installation instructions. This will prevent loss of pump prime and possible interruptions in the water supply to the house. Remove the priming plug from the pump and add the specified volume (See Pump Installation Instructions) of water to the pump. Either re-install the priming plug or install a 3/8" NPT x 2" long pipe nipple and attach a 1/4" NPT Pressure Gauge with with 1/4" x 3/8" FNPT Reducer to the pipe nipple (Fig. 2).

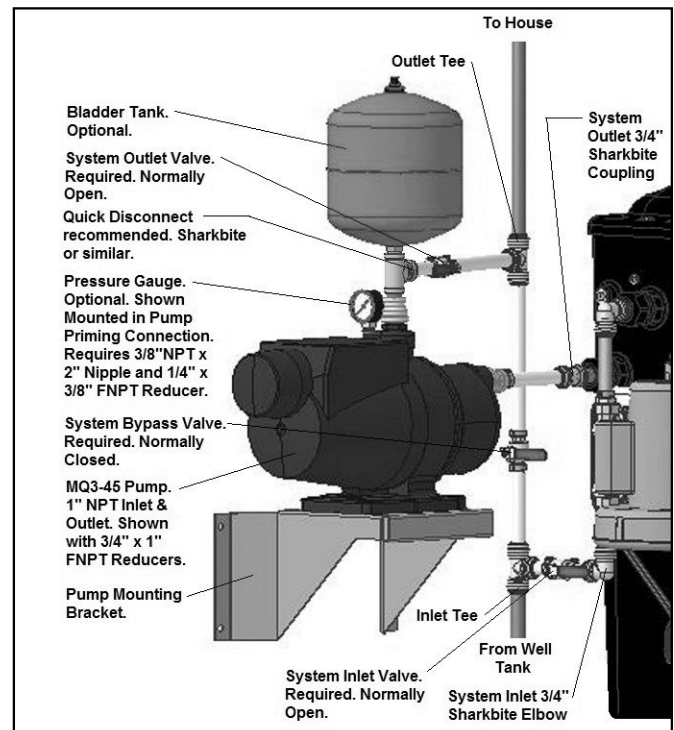

Figure 2
Pump & Bypass Assembly

3. Sit the pump onto the mounting bracket and connect pump inlet to system outlet. The system outlet is provided with a $\frac{3}{4}$ " Sharkbite Connection suitable for $\frac{3}{4}$ " Nominal Copper Tube or Pex Tube; insertion length into Sharkbite Fitting is 1". Additional fittings will be required to connect the tube to the 1" MNPT threaded connection on the MQ3-45 Pump. Fittings required may vary with pump used. Cut the tubing to the length required to align the pump base with the mounting holes in the pump mounting bracket. Bolt the pump to the mounting bracket.

4. With the System located as desired, install the pipe/tube from the pump discharge to the desired location of supply to house. At the house end a tee is required to accommodate supply to house and to System Bypass Connection. Fittings will be required to connect to the 1" MNPT threaded connection on the MQ3-45 Pump. Fittings required may vary with pump used. The optional Bladder Tank has a $\frac{3}{4}$ " MNPT threaded connection. A tee will be required if the bladder tank is installed, otherwise an elbow may be used at the same location. To facilitate removal of pump for service, a quick disconnect (sharkbite as illustrated, or pipe union) is recommended on the pump side of the required System Outlet Valve (normally open ball valve).

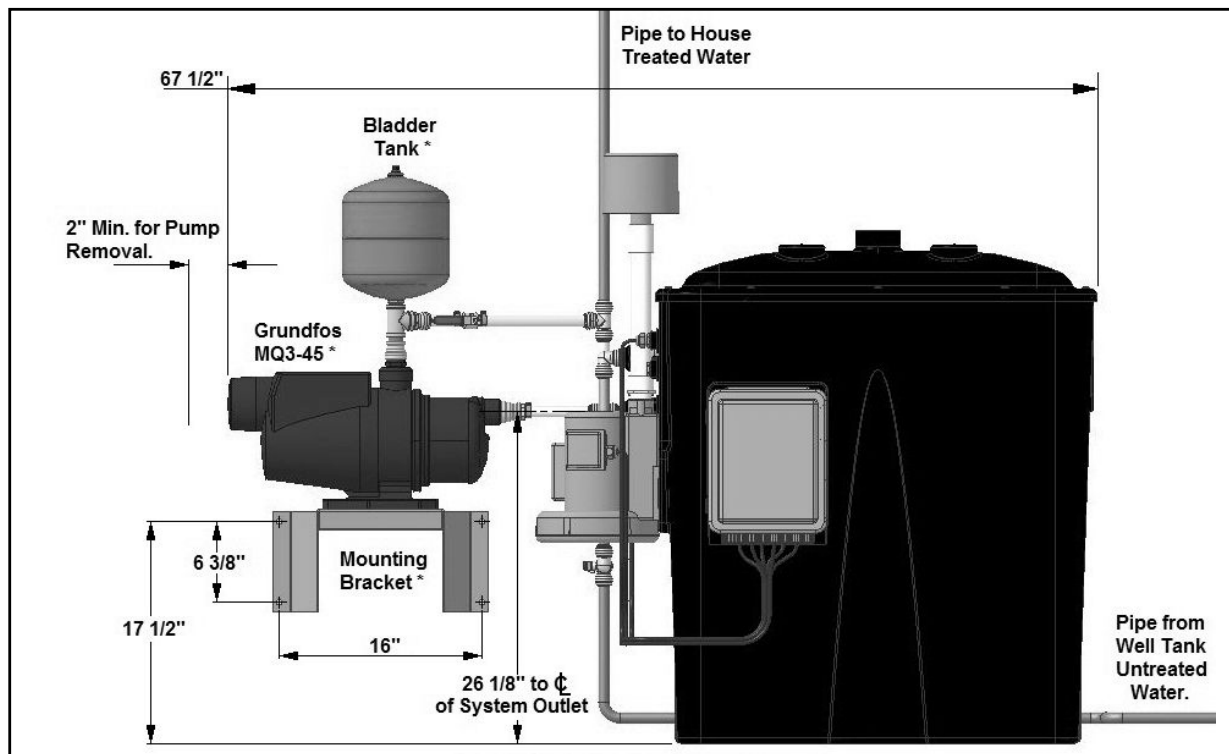

Figure 3
Installed 433 ND System

5. Install pipe/tube from System inlet (Fig. 2) to the desired location of the supply from the well tank. At the supply end a tee is required to accommodate supply from the well and the system bypass connection. The system inlet is provided with a $\frac{3}{4}$ " Sharkbite Elbow suitable for $\frac{3}{4}$ " Nominal Copper Tube or Pex Tube, insertion length into Sharkbite Fitting is 1". A System Inlet Valve (normally open ball valve) is required between the tee and Sharkbite Elbow.

6. Install the pipe/tube between the tees at the desired locations of the supply to house and the supply from well. A System Bypass Valve (Normally Closed Ball Valve) is required between the tees.

2.3. Plumbing Hook-up

All Plumbing should be performed in accordance with Local and State Codes by a Qualified Plumber.

1. Shut off the water main valve located after the pressure tank.

2. Drain the water line.

3. Plumb the system into the water line after the pressure tank and all other water treatment equipment.

4. Plumb the water line from the existing pressure tank into the Inlet Tee.

5. Plumb the water line to the house into the Outlet Tee (Fig. 2, 4 or 5 depending on System and Pump). A flow restrictor or gate valve in the water line to the house is required for balancing the system flow. A Bladder Tank, minimum capacity 5 gallons is required for 433-S50 Systems (20gal. min. for 433-S50X).

WARNING: Bladder Tank must be supported by hanger attached to wall or joist.

6. Making sure the Bypass valve is open and Inlet and Outlet Valves are closed, slowly open the water main valve and check for leaks.

7. Slowly change bypass to the "service" configuration, Bypass valve closed, inlet and outlet valves open. Prime jet pump as per Manufacturers Instructions (See enclosed Jet Pump Manual) if not previously primed. Note that integral pump on 433-S75 and 433-S50 systems will self prime when the system tank is filled.

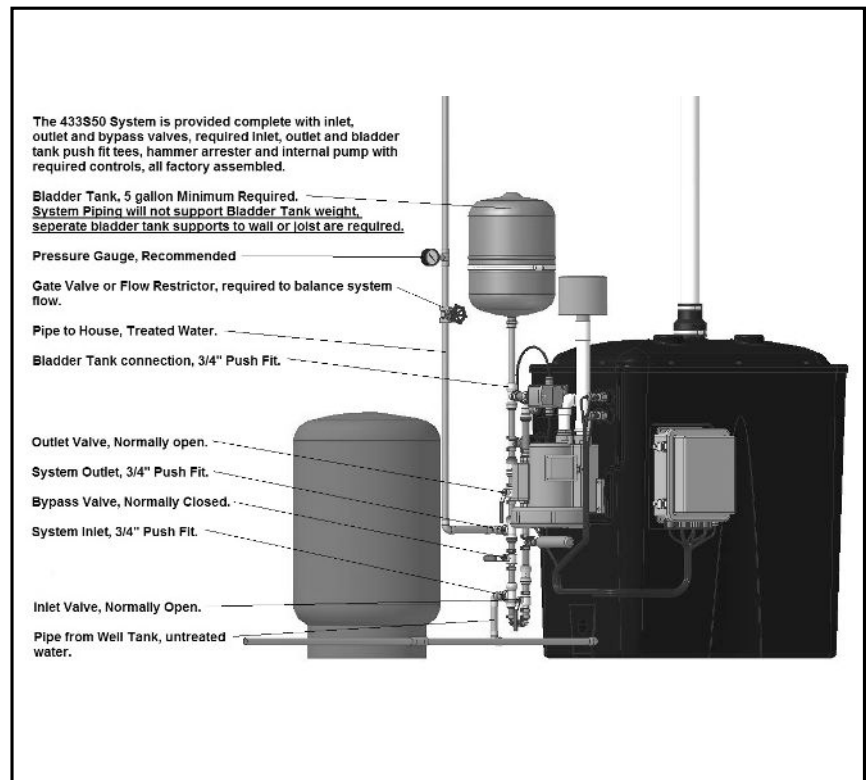

Figure 4
Plumbing Installation 433S ND System

433-S50X Systems are provided without a pressure regulator or other device which would enable the use of small inline bladder tanks. The pressure switch is factory set but must be installed on the bladder tank tee by the installer. Type MC Armored Cable with connectors and clips are provided to connect the pressure switch to the system control box. Inlet, outlet and bypass valves are not provided. Sharkbite inlet and outlet connections are provided. Hammer Arrester and Internal Pump with controls supplied factory assembled.

3/4" Sharkbite Outlet Elbow

Bladder Tank Required. 20 Gallon capacity minimum required for 433-S50X AirRaider System.

Existing Well Tank. Pressure Switch, Drain Valve, Pressure Relief Valve and Pressure Gauge usually located at the well tank are not illustrated but may be required by local or State Codes.

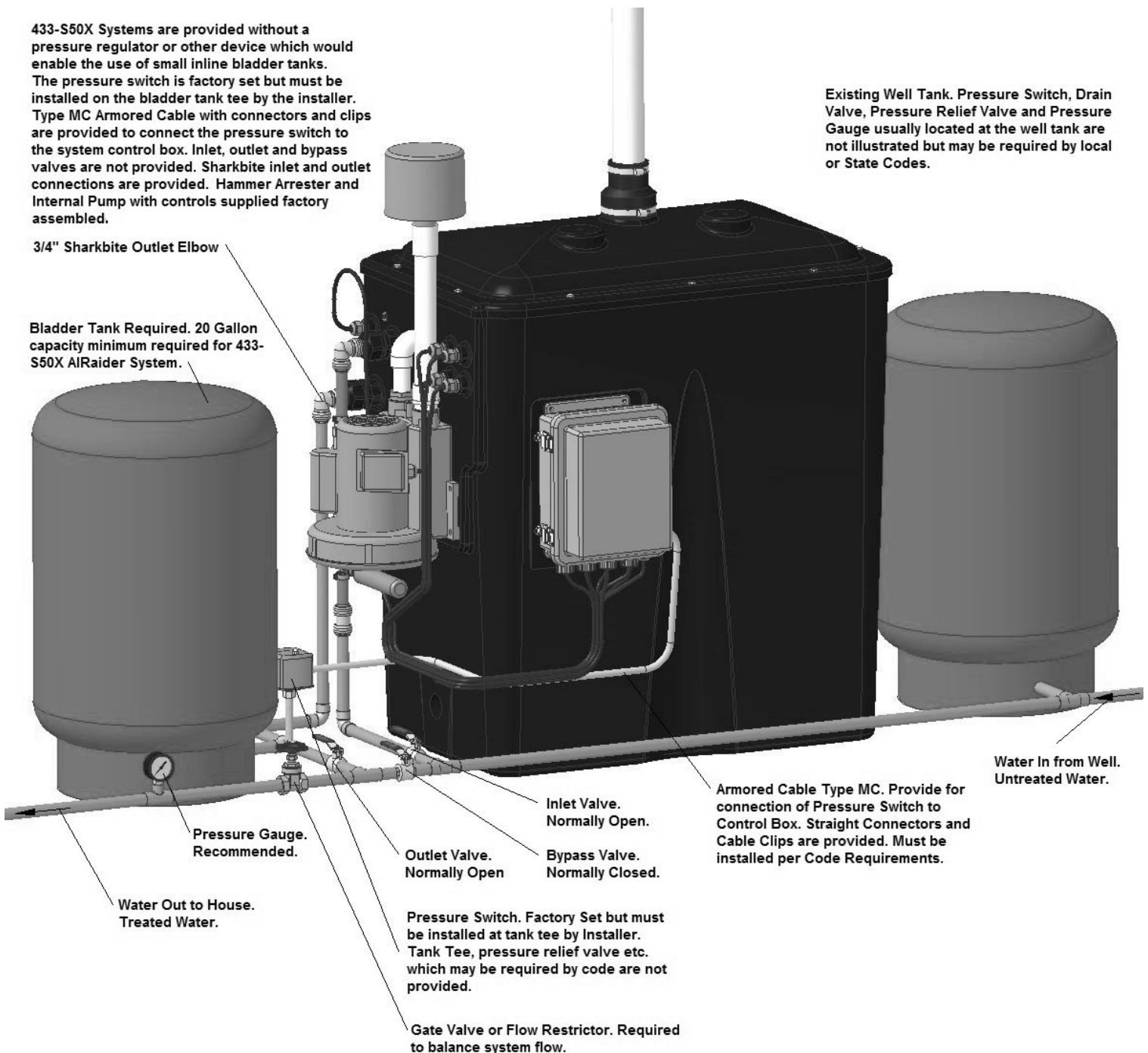

Figure 5

Plumbing Installation 433-S50X

2.4. Electrical Hook-up

All Electrical Work should be performed in accordance with Local and State Codes, and NFPA National Electrical Code, Standard #70 by a Qualified and Licensed Electrician .



WARNING: Never perform electrical work while standing in water. Do not attempt wiring on a live circuit.

WARNING: Power Supply Voltage must match the voltage marked on the System Nameplate. Improper wiring may result in system damage.

1. Turn main power switch, located on the AIRaider™, to the “Off” position.
2. Connect the Jet Pump power cord to the Jet Pump. (Does not Apply to 433-S50 or 433-S50X Systems, pump is factory connected) Note the Jet Pump power cord from the AIRaider™ is provided with an electrical receptacle. The Jet Pump may be connected either by connecting a suitable power lead with plug and plugging into the receptacle or by removing the receptacle from the Jet Pump power cord and connecting the power cord directly to the pump. Follow wiring instructions located in the enclosed Jet Pump Manual.

Warning: Never remove the Receptacle from the Jet Pump Power Cord without connecting the wires thus exposed to the jet pump, inside the Jet Pump Electrical Enclosure. Always secure the Jet Pump Enclosure Cover after making electrical connections.

3. On 433-S50X units only the installer may need to disconnect the Armored Cable supplied in order to install the Pressure Switch. The Armored Cable may require trimming to the desired length before reconnecting. Connect per the wiring diagram Figure 8 Page 14.
4. Make sure all connections in the control panel are tight.
5. Bring in power to the control panel using the hole provided, either an appropriate strain relief bushing, or electrical conduit fitting(s), with correctly rated electrical wire or cable must be used in accordance with all applicable Electrical Codes.
6. Connect the power line to the control panel as shown in the applicable wiring diagram (See Figures 6, 7, 8, 9 - on pages 12-15).
7. Connect power line to power source *. The required Voltage is either 120V or 240V and is indicated by an “X” marked in the check box next to either the 120V or 240V marking on the nameplate. Follow all code requirements regarding wire and circuit breaker size.

*** Manufacturer recommends that the AIRaider™ System be directly wired to the panel on a dedicated circuit.**

433ND 115/230V - 1Ph-60Hz Power Supply

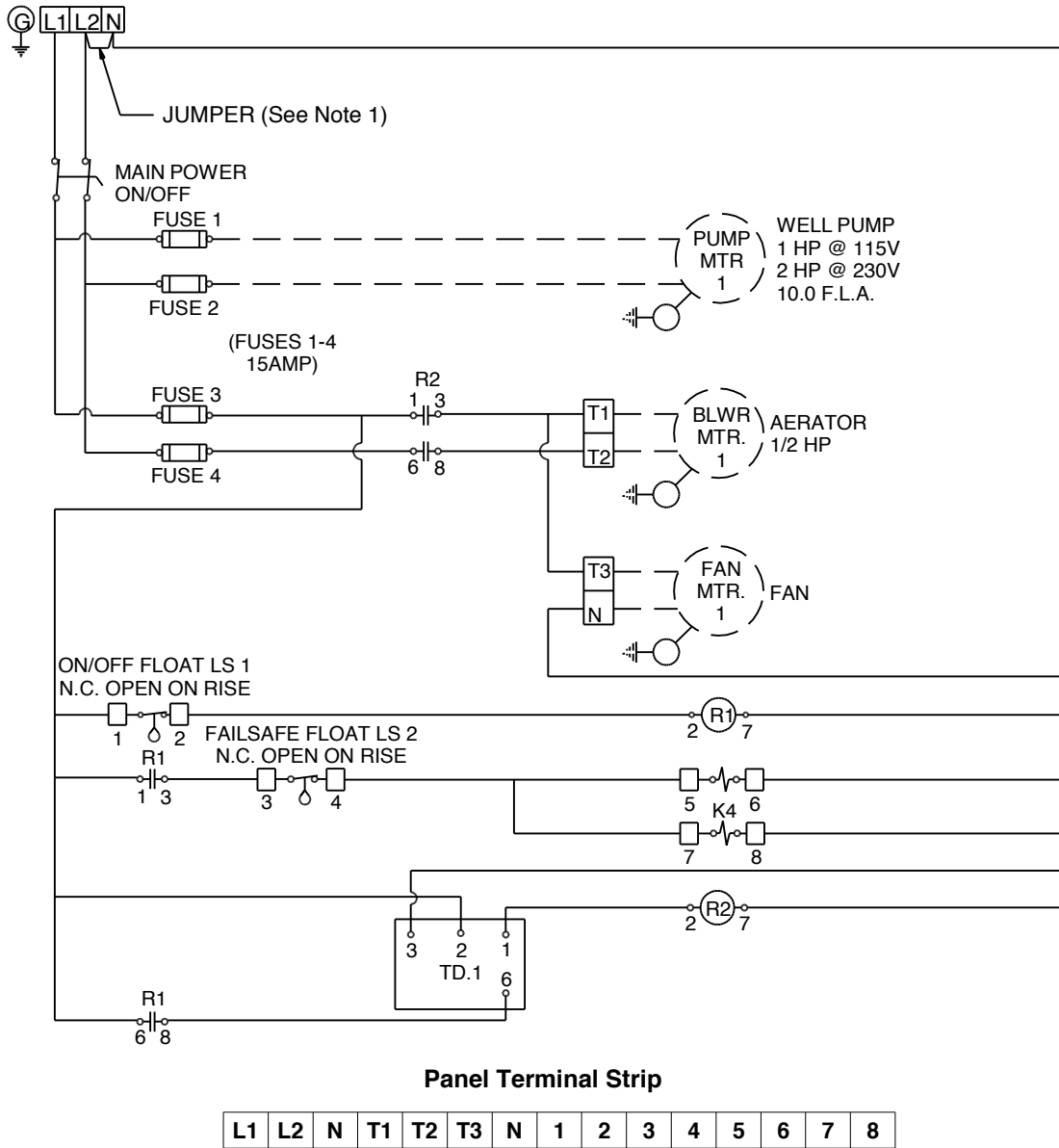

Component	Black	White	Red	Green
Power In (115V)	L1	N		Ground
Power In (230V)	L1	N	L2	Ground
On/Off Float LS 1 (lower)	1	2		
Fail Safe Float LS 2 (upper)	3	4		
Solenoid	5	6		Ground
Solenoid	7	8		Ground
Blower	T1	T2		Ground
Pump	Fuse 1	Fuse 2		Ground
Vent Fan (if used)	T3	N		Ground

Note 1: Remove Jumper from L2 to N for 230V operation (see Note 2).

Note 2: 230V operation requires a Power Connection consisting of a Three Wire Cable with a Ground

Figure 6

AIRaider™ 433 Wiring Diagram 115V/230V

433-S50 ND with 1/2HP Submersible Pump 115V-1PH-60Hz Power Supply

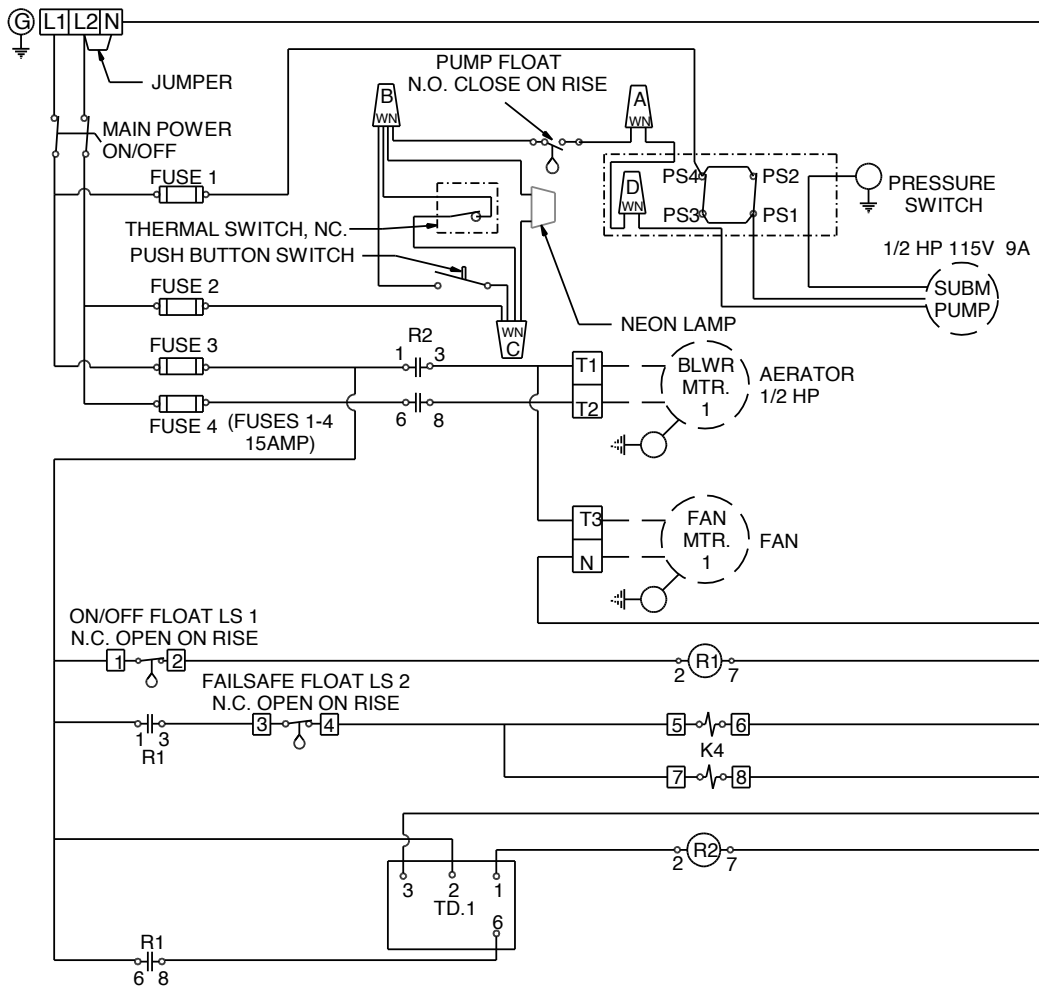

Panel Terminal Strip

L1	L2	N	T1	T2	T3	N	1	2	3	4	5	6	7	8
----	----	---	----	----	----	---	---	---	---	---	---	---	---	---

Component	Black	White	Green
Power In (115V)	L1	N	Ground
On/Off Float LS 1 (middle)	1	2	
Fail Safe Float LS 2 (upper)	3	4	
Solenoid	5	6	Ground
Solenoid	7	8	Ground
Blower	T1	T2	Ground
Pump	PS-1	WN D	Ground
Vent Fan (if used)	T3	N	Ground
Pump Float (lower)	WN A	WN B	
Pressure Switch	FUSE 1-PS4	WN A-WN D	Ground
Thermal Switch	WN B	WN C	
Neon Lamp	WN B	WN C	
Jumper Lead(3)	L2-N PS1-PS3 PS2-PS4		

Figure 7

AIRraider™ 433-S50 Wiring Diagram 115V

433-S50X with 1/2HP Submersible Pump 115V-1Ph-60Hz Power Supply

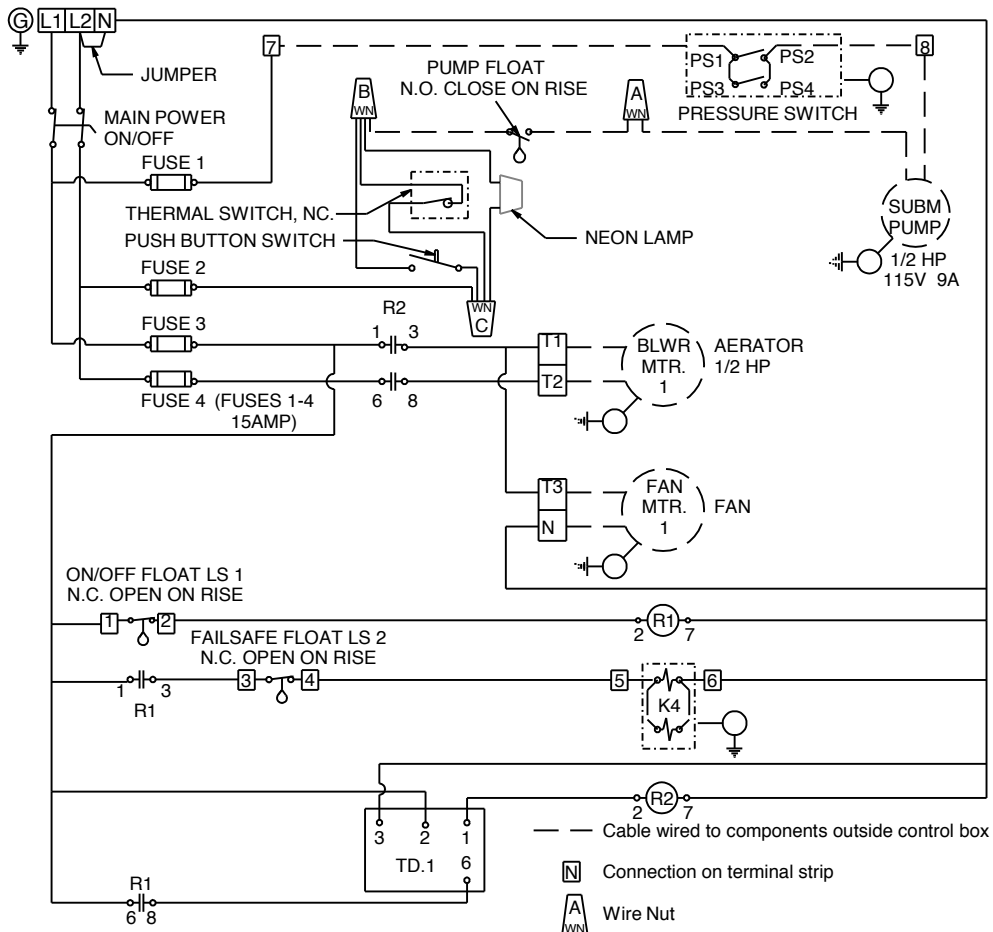

Panel Terminal Strip

L1	L2	N	T1	T2	T3	N	1	2	3	4	5	6	7	8
----	----	---	----	----	----	---	---	---	---	---	---	---	---	---

WIRING PROCEDURE:

1. Remove Jumpers from panel terminals 4/5 to 7 and N to 8.
2. Run 16ga. black wire from Fuse 1 to rear of panel terminal 7.
3. Run 16ga. black wire from Fuse 2 to wire nut C.
4. Connect components as detailed in table below.

Component	Black	White	Green
Power In (115V)	L1	N	Ground
On/Off Float LS 1 (middle)	1	2	
Fail Safe Float LS 2 (upper)	3	4	
Solenoids	5	6	Ground
Blower	T1	T2	Ground
Pump	8*R	WN A	Ground
Vent Fan (if used)	T3	N	Ground
Pump Float (lower)	WN B	WN A	
Pressure Switch	7-PS1	PS2-8	Ground
Thermal Switch	WN B	WN C	
Neon Lamp	WN B	WN C	
Push Button Switch	WN B	WN C	
Jumper Lead(3)	L2-N PS1-PS3 PS2-PS4		

8*R CONNECT BLACK PUMP LEAD TO CONNECTION ON REAR SIDE OF TERMINAL 8

Figure 8

AIRaider™ 433-S50X Wiring Diagram 115V

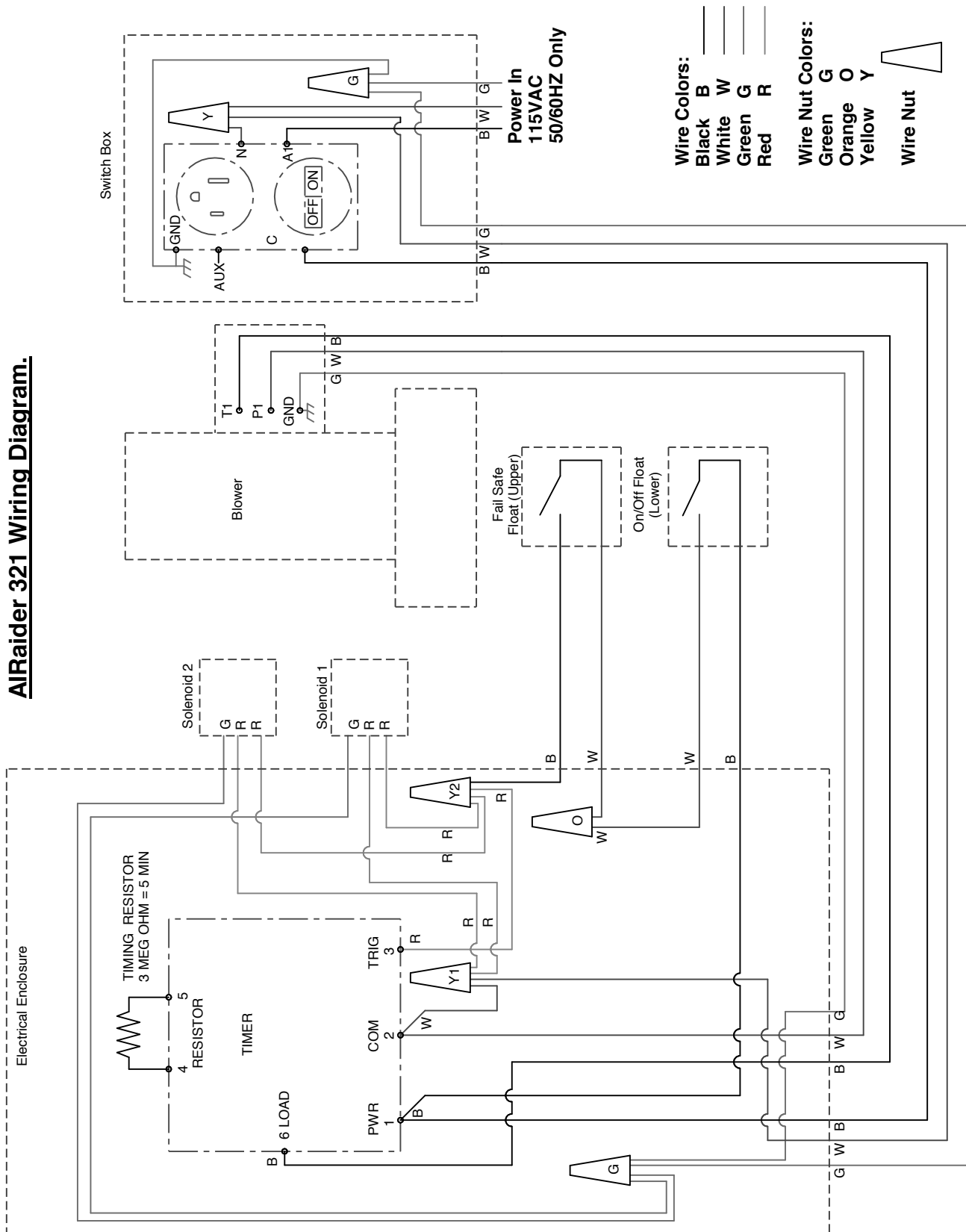

Figure 9
AIRraider™ 321 Wiring Diagram

2.5 Vent Line Installation

Use only 2", 3" or 4" Schedule 40 PVC or equivalent pipe for vent line. Follow all applicable AARST, EPA, and/or State Standards for Radon or VOC venting.

1. Place the lid of the AIRraider™ on to the tank and clamp into place using the Hex Head Screws and Washers provided.

2. Connect vent line to AIRraider™ lid using the enclosed rubber coupling (See Fig. 10).

3. The vent line must be routed in a manner that allows the system to exhaust above the level of the roof (see Fig. 11).

Note: When "Freeze Up" is possible a minimum pipe diameter of 3" is recommended (See Fig. 12).

4. The vent line must be pitched back toward the system to prevent condensation build up.

5. Cement all fittings in a manner that ensures no leakage will occur. Be certain to use cement that is suitable for potable water applications.

6. Install weather cap on top of the vent line. This cap should not restrict air flow and must prevent rain, snow and other contaminants from entering the vent line.



Figure 10
Vent Line Connection

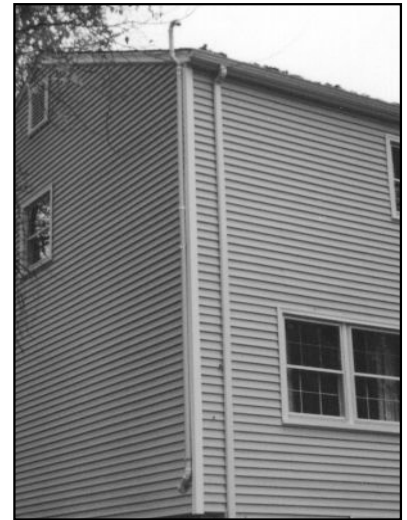

Figure 11
Vent Line Installation (2 inch)



Failure to install a proper vent line may cause contamination of the water, outgassing of contaminants into the building, and/or limit system performance.

** The Manufacturer has found that vent lines less than 250 equivalent linear feet do not cause a decrease in contaminant removal percentages.*

90° Bend = 15 Equiv. Linear Ft ; 45° Bend = 7 Equiv. Linear Ft.



Figure 12
Vent Line Installation (3 inch)

2.6 Install Air Filter (Fig. 12)

1. Install air filter provided using the PVC pipe and fittings provided (Fig 14).

2.6.1 Remote Air Intake (Fig. 13)

If a Remote Air Intake is required because of Air Quality or Quantity issues then Use Only 1-1/4" or larger Schedule 40 PVC or equivalent pipe for the air intake line.

1. Connect air intake line to the blower using the proper reducer coupling (See Fig. 13).

2. Run the intake line from the pipe connection on the blower to the location selected for air intake.

Note: A rubber coupling or similar means to disconnect the intake line from the is recommended.

3. Connect the Air Filter to the vent line using the proper reducer coupling.

If the air intake is located outside, the filter or intake must be mounted high enough off the ground to prevent the drawing in of snow, water and other contaminants. Do not locate the air intake in the vicinity of vents from furnaces, barbecue grills, etc.

Note: In-Line Air Filters are also available from the Manufacturer.



Figure 13
Air Filter

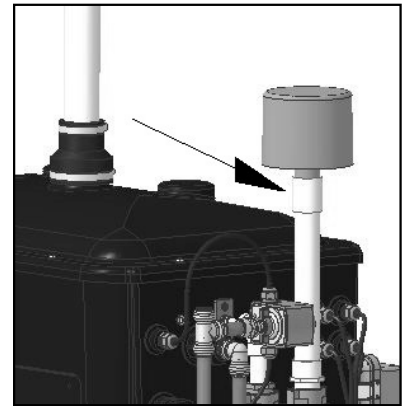

Figure 14
Air Intake Connection

2.7. System Start-Up

1. Remove cover and lid and pour $\frac{1}{4}$ cup of chlorine into the first chamber. (This will disinfect the system.) Replace the lid making sure all screws are secure.

2. Check that all plumbing and electrical connections have been properly completed.

3. Slowly change bypass to the "service" configuration. Check for leaks.

4. Turn power switch for AIRRaider™ to "On". Solenoid Valves will now open allowing water into the system. The aeration process will also start. Check for leaks.

5. Allow the AIRRaider™ to fill with water.

6. **On 433-S50 & 433-S50X Systems** the submersible pump installed in the Aeration Tank will self prime when the rising water level lifts the pump float and the pump starts. Follow pump manufacturer's instructions to prime other external pumps. The normal operating range is nominally 40 PSI – 60 PSI* but will vary (Pressure Switches on 433-S50 & 433-S50X factory set at 38 PSI - 55 PSI approx.).

Do Not Attempt to Adjust the Pressure on 433-S50 or 433-S50X Systems, as this may result in the pump not shutting down as it attempts to reach too high a set pressure. This problem may not occur immediately but can occur later when a low voltage supply occurs due to high electrical demand or other external factors. The factory pressure setting is deliberately less than maximum to provide an allowance for a low voltage supply event. Continuous operation of the pump when there is no water demand will overheat the system causing the thermal overload to trip and consequent pump shut down.

Note: Priming process for the jet pump and pressure settings may vary with repressurization system.

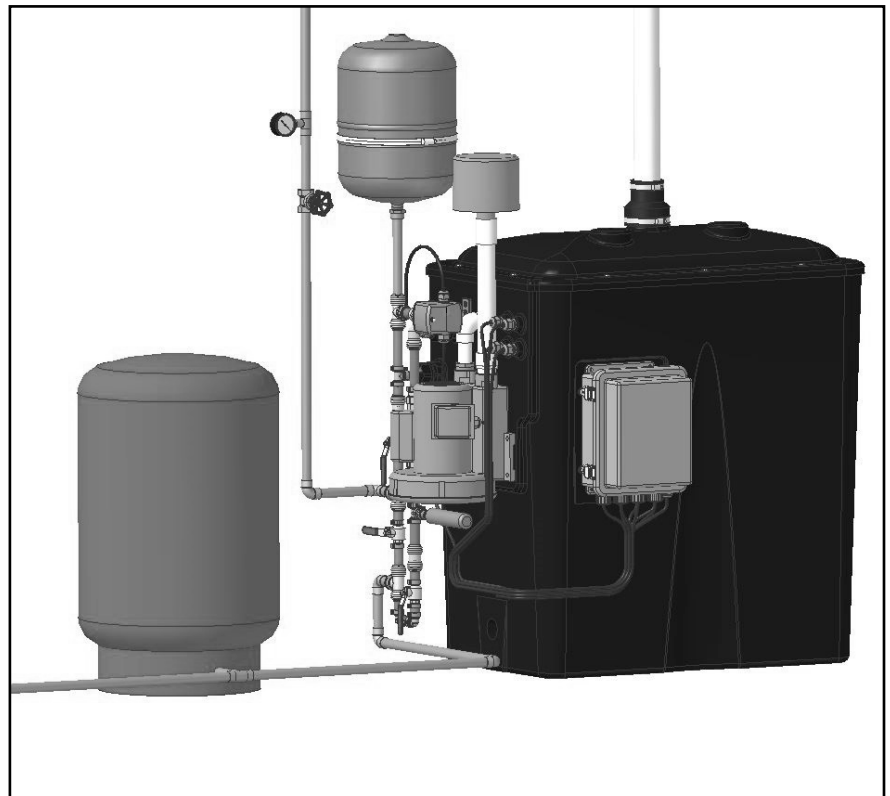
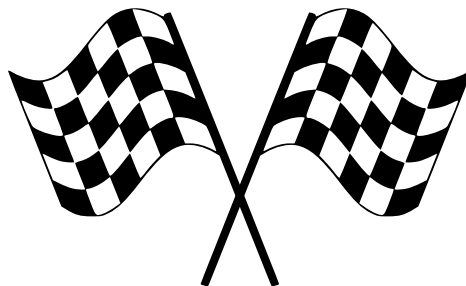

Figure 15
Installed AIRRaider™ 433-S50

2.8 System Check

1. Run the system through a couple of cycles to ensure all components are working properly.
2. The blower timer is preset for 5 minutes delay. After the solenoid valves shut, check that the blower continues running for the preset number of minutes delay.
3. Open the tank and check the system.
 - a. Remove the tank lid.
 - b. Lower the water level in the tank by opening a bath tub tap, or similar, within the residence. The floats will fall with the water level. The minimum water level is reached when the lower float drops (except on 433-S50 & 433-S50X systems where minimum water level occurs when the middle float drops). There will be an audible click and the solenoids will open allowing the tank to start filling; the blower should also start running. The water level must rise regardless of how many taps are open within the residence.
 - c. While the tank is filling lift the lower float (middle float on 433-S50 & 433-S50X), water in flow should stop and the blower will remain running (until the end of the preset delay). Release the lower float.
 - d. While the tank is still filling lift the upper float; water in flow should stop and the blower will remain running. Release the upper float. Pushing down the lower float on 433-S50 and 433-S50X Systems will shut off the pump.
 - e. Remember to shut off any open taps within the residence.
4. Replace the lid and secure with the fasteners provided. With the System running check the lid for air leaks between lid gasket and tank. If leaks occur the fasteners should be tightened until leaks are eliminated.
5. Make sure you have properly labeled the system with the necessary installer information (i.e. company name, phone #, date installed, etc.) and you have left all system information with the home owner.
6. The AIRaider™ System is now operational.



3. Retesting

After the AIRaider™ installation, the installer should perform another water analysis to ensure proper system performance. This sample should be performed one week after the date of installation.

Sampling Procedure:

1. Remove aerator from faucet or spigot, if applicable.
2. Run water so that the AIRaider™ operates for two cycles.
3. Turn off water for 5 minutes.
4. Turn water on and proceed with sampling as per the laboratory instructions.

4. Maintenance

Proper maintenance of the AIRaider™ can prevent possible system failure and provide years of trouble free service.

4.1. Six Month Service (recommended)

The following procedures should be followed to maintain the AIRaider™:

- Check and/or clean the blower air intake filter.
- Check and/or clean any filters or strainer installed on the inlet line to the AIRaider™. In installations with particularly high levels of sediment, cleaning of filters may be required more frequently.
- Check and clean inlet screen on pump.
- Using a wet/dry vac, clean sediment from bottom of aeration tank if necessary.
- Clean (if necessary) tank and diffusers of all mineral buildup.
- Chlorinate tank and lines by pouring ¼ cup of chlorine into the first aeration chamber.
- Check all control panel connections and electrical components (blower, pump, timer, fuses, etc.) for proper operation.
- Check float switches for proper operation.
- Inspect vent line for possible obstructions.
- Run system through two cycles to ensure good working order.

4.2 Annual Service (required)

The following procedures should be followed annually to maintain the AIRRaider™:

- Clean solenoids and switch coil locations.
- Check all hose connections.
- Check and/or clean the blower air intake filter.
- Check and/or clean any filters or strainer installed on the inlet line to the AIRRaider™.
- Check and clean inlet screen on pump.
- Using a wet/dry vac, clean sediment from bottom of aeration tank if necessary.
- Clean (if necessary) tank and diffusers of all mineral build up.
- Chlorinate tank and lines by pouring ¼ cup of chlorine into the first aeration chamber.
- Check all control panel connections and electrical components (blower, pump, timer, fuses, etc.) for proper operation.
- Check float switches for proper operation.
- Inspect vent line for possible obstructions.
- Run system through two cycles to ensure good working order.
- Perform Water Test.

* *Every 3 years during the annual service replace all hoses.*

** *Every 5 years during the annual service replace the solenoid valves.*

Symptom

Solution

No water in house

- Check power: Switch in on position, circuit breaker at panel in on position, fuses in control panel intact.
- Check pressure in tank. If below the proper settings, reset the pump as described in System Start-up (p. 17).
- Bypass System. If there is still no water, main well pump may not be functioning.
- Check on/off float for proper operation. Replace if necessary.

System running dry

- Check sediment strainer and/or filter (if applicable) and clean if necessary.
- Install a flow restrictor or meter down the ball valve until the AIRaider™ outflow is 1 GPM or more less than the water flow entering the system.

Water not entering system

- Check solenoids for proper operation. Replace if necessary.
- Check float switches for proper operation. Replace if necessary.
- Check sediment strainer and/or filter (if applicable) and clean if necessary.

Jet Pump not functioning

- Check fuse in control panel.
- Check breaker at electrical panel.
- Replace jet pump if necessary.

Pressure in tank is less than 40 PSI

- Reset jet pump as described in System Start-up (p. 17).
- Check bladder tank.
- Replace jet pump and/or bladder tank as necessary.

Low water flow at faucets

- Clear sediment strainers on faucets.
- Clear pump inlet screen/water injector.
- Replace pump if necessary.

Loud banging when solenoids shut

- Install water hammer suppressor or loop of flexible hose in pump inlet line.
- Shorten the length of pipe between the well pressure tank and the system.

Solenoids chatter when closing

- Check On/Off float for proper operation. Replace if necessary.

Blower not running

- Check fuses in control panel.
- Replace timer if necessary.
- Replace blower if necessary.

Blower does not stop running

- Check On/Off float for proper operation.
- Check Timer Settings.
- Replace Timer Relay if necessary.

Pump is short cycling

- Bladder tank may be ruptured. Replace if necessary.
- Check pressure switch on pump for proper operation.

Pump won't shut off

- Call for support.

LIMITED WARRANTY

Subject to applicable consumer protection legislation, RadonAway warrants that the AIRaider™ will be free from defective materials and workmanship for the period of two (2) years from the date of purchase.

Warranty is contingent on installation in accordance with the instructions provided. This warranty does not apply where repairs or alterations have been made or attempted by others; or the unit has been abused or misused. Warranty does not include damage in shipment unless the damage is due to the negligence of RadonAway. To make a claim under these limited warranties, you must return the defective item to RadonAway. All other warranties, expressed or written are not valid. RadonAway is not responsible for installation or removal cost associated with this warranty. In no case is RadonAway liable beyond repair or replacement of the defective product FOB RadonAway.

RADONAWAY SPECIFICALLY DISCLAIMS ANY WARRANTY OF FITNESS FOR A PARTICULAR PURPOSE.

THERE ARE NO WARRANTIES WHICH EXTEND BEYOND THE DESCRIPTION ON THE FACE HEREOF. THERE IS NO WARRANTY OF MERCHANTABILITY. ALL OTHER WARRANTIES, EXPRESSED OR WRITTEN, ARE NOT VALID.

In order to obtain service under this warranty, the consumer must contact the installer or dealer where the unit was purchased. The installer or dealer must then contact RadonAway directly for a Return Merchandise Authorization (RMA) number and shipping information. No returns can be accepted without an RMA. RadonAway may require the defective part(s) to be returned to place of manufacture (freight pre-paid) to process the warranty claim. Defective part(s) covered under this warranty will be replaced or repaired at the place of manufacture and returned to the installer or dealer (freight pre-paid). In replacing or repairing parts or products, RadonAway reserves the right to make such changes in the details of design construction, arrangement or make materials as shall in its judgment constitute an improvement over former practice.

Record the following for your records:

Serial No. _____ Date Purchased: _____



3 Saber Way
P.O. Box 8244
Ward Hill, MA 01835

Phone: (800) 767-3703
Fax: (978) 521-3964
E-mail: sales@radonaway.com



3 SaberWay
P.O. Box 8244
Ward Hill, MA 01835

Phone: (800) 355-0901
Fax: (978) 521-3964
E-mail: sales@spruce.com